



# CFORCE OWNERS MANUAL 625

## READ THIS MANUAL CAREFULLY

It contains important safety information.  
This ROV should not be ridden by anyone under  
16 years of age. Passenger under 12 are prohibited.

# TABLE OF CONTENTS

Foreword .....	1
Welcome .....	1
Signal Words .....	2
Introduction .....	5
Vehicle Identification Number .....	5
Technical Specification .....	6
Operator Safety .....	12
Age Restrictions .....	12
Know Your Vehicle .....	12
Equipment Modifications .....	13
Avoid Burns from Hot Parts .....	14
Pulling a Trailer .....	14
Safety Training .....	15
Hazardous Operation Warnings .....	15
Safe Riding Gear .....	39
Safety Decals and Locations .....	40
Features and Controls .....	47
Left Hand Controls .....	47
Right Hand Controls .....	51

Foot Controls.....	56
Vehicle Features .....	58
CVT System .....	67
How To Avoid CVT Drive Belt and Component Failure .....	68
Dashboard Indicators and Warnings .....	70
<b>Operation of Your Vehicle .....</b>	<b>78</b>
Break-In Period .....	78
Pre-Ride Inspection.....	80
Starting the Engine.....	81
Gear Selector Operation .....	83
Hauling and Towing Cargo .....	86
Load Distribution .....	88
Driving Safely .....	94
<b>Maintenance .....</b>	<b>110</b>
Severe Use Definition .....	110
Periodic Maintenance Schedule and Icon Key.....	111
Pre-Ride Maintenance Checklist.....	113
Break-In Maintenance Checklist .....	115
Periodic Maintenance Schedule.....	117
Maintenance Procedures .....	124

<b>Cleaning and Storage .....</b>	<b>164</b>
Transporting the Vehicle .....	168
<b>Vehicle Issue Diagnosis .....</b>	<b>169</b>
Engine doesn' t turn over .....	169
Engine pings or knocks .....	169
Engine stops or loses power .....	170
Engine turns over, Fails to start.....	171
Engine backfires .....	172
Engine runs irregularly, stalls or misfires.....	172
EFI Malfunction Indicator Light.....	174
EPS Malfunction Indicator Light.....	175
<b>Declaration .....</b>	<b>178</b>
Declaration of Drivers exposure to noise level .....	178
Declaration of Vibration declaration .....	179
<b>CFMOTO LIMITED WARRANTY .....</b>	<b>180</b>

## FOREWORD

### Foreword

#### Welcome

Thank you for purchasing a CFMOTO vehicle, and welcome to our world-wide family of CFMOTO enthusiasts. Be sure to visit us at [www.cfmoto.com](http://www.cfmoto.com) for the latest news, new product introductions, upcoming events, and more.

CFMOTO, an international company that specialises in the development, manufacture and marketing of large displacement motorcycles, all terrain vehicles, utility vehicles, and core components (power sports liquid cooling engines, frames, etc). Founded in 1989, CFMOTO is always devoted to the developing routine of independent brand cultivation and independent R&D innovation. Now, CFMOTO products are distributed through more than 2000 companions worldwide for more than 100 countries and areas. CFMOTO is edging into the advanced ranks in the world in the power sports industry, and aims to supply superior products to dealers and fans globally.

For safe and enjoyable operation of your vehicle, be sure to follow the instructions and recommendations in this owner's manual. Your manual contains instructions for minor maintenance. Information about major repairs is outlined in the CFMOTO Service Manual.

Your CFMOTO dealer knows your vehicle best and is interested in your total satisfaction. Be sure to return to your dealership for all of your service needs during, and after, the warranty period.

Due to constant improvements in the design and quality of production components, some minor discrepancies may result between the actual vehicle and the information presented in this publication. Depictions and/or procedures in this publication are intended for reference use only.

## FOREWORD

### Signal Words

A signal word calls attention to a safety message or messages, a property damage message or messages, and designates a degree or level of hazard seriousness. The standard signal words in this manual are WARNING, CAUTION and NOTE or NOTICE.

Familiarize yourself with all laws and regulations concerning the operation of this vehicle in your area. We strongly advise you to strictly follow the recommended maintenance program outlined in your owner's manual. This preventive maintenance program is designed to ensure that all critical components on your vehicle are thoroughly inspected at specific intervals.

The following signal words and symbols appear throughout this manual and on your vehicle. Your safety is involved when these words and symbols are used. Become familiar with their meanings before reading the manual.

#### **WARNING**

This safety alert and icon indicates a potential hazard that may result in serious injury or death.

#### **CAUTION**

This safety alert and icon indicates a potential hazard that may result in minor or moderate personal injury and/or damage to the vehicle.

#### **CAUTION**

This safety alert without an icon indicates a situation that may result in damage to the vehicle.

#### **NOTE or NOTICE**

A note or notice will alert you to important information or instructions

## **FOREWORD WARNING**

**Improper vehicle use can result in SEVERE INJURY or DEATH**

### **NEVER Operate:**

- Without first viewing owner's manual and quick start guide.
- Carrying more passengers than the rated passenger capacity.
- Use ALCOHOL or DRUGS before or while driving this vehicle.
- With Non-CFMOTO approved accessories.

### **ALWAYS:**

- Keep hands and feet inside vehicle.
- Reduce speed and use extra caution when carrying a passenger.
- Operate slowly in reverse-avoid sharp turns or sudden braking.
- Make sure passenger reads and understands all safety labels.
- Watch for branches or other hazards that could enter vehicle.
- Use safety belt during operation.

**Locate and Read Owner's manual, Follow all INSTRUCTIONS and WARNINGS. If Owner's manual is missing, contact a CFMOTO dealer for replacement.**

FOREWORD  
**⚠️ WARNING FOR TYPE I VEHICLES**

(1-person vehicle)

**Improper vehicle use can result in SEVERE INJURY or DEATH**



**ALWAYS  
USE AN  
APPROVED  
HELMET AND  
PROTECTIVE  
GEAR**



**NEVER CARRY  
PASSENGERS**



**NEVER  
USE WITH  
DRUGS OR  
ALCOHOL**

FOREWORD  
**⚠️ WARNING FOR TYPE II VEHICLES**

(2-person vehicle)

**Improper vehicle use can result in SEVERE INJURY or DEATH**



**ALWAYS  
USE AN  
APPROVED  
HELMET AND  
PROTECTIVE  
GEAR**



**NEVER  
CARRY MORE  
THAN ONE  
PASSENGER**



**NEVER  
USE WITH  
DRUGS OR  
ALCOHOL**

**FOREWORD**  
**READ THE OWNER'S MANUAL**

**FOLLOW ALL INSTRUCTIONS AND WARNINGS**

** WARNING**

Read, understand, and follow all of the instructions and safety precautions in this manual and on all product labels. Failure to follow the safety precautions could result in serious injury or death.

** WARNING**

The engine exhaust gas from this product contains CO, which is deadly gas and could cause headache, giddy, disgusting or lose consciousness, even death.

** WARNING**

Engine box cover, brake disc and muffler exhaust pipe will be hot easily after long period usage. Avoid being burned by those parts.

## INTRODUCTION

### Introduction

#### Vehicle Identification Number

Record your vehicle's identification numbers in the spaces provided. Remove the spare key and store in a safe place. Your key can be duplicated only by mating a key blank with one of your existing keys.

If both keys are lost, the complete lock assembly must be replaced.

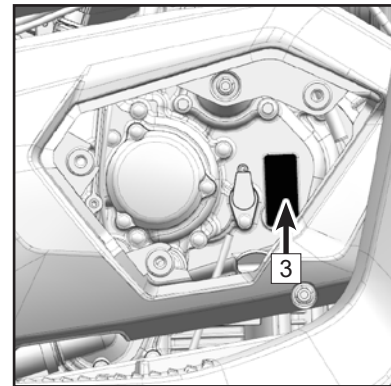
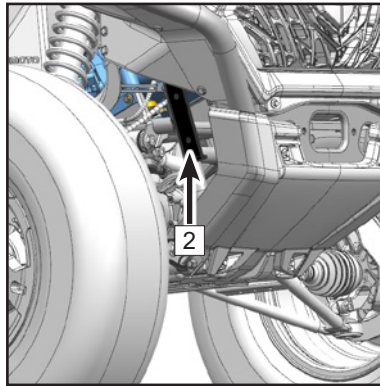
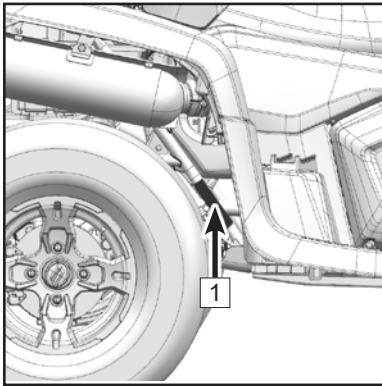

1 Vehicle identification number: \_\_\_\_\_

2 Vehicle model number: \_\_\_\_\_

3 Engine serial number: \_\_\_\_\_

## INTRODUCTION

### Technical Specification

Item	CFORCE 625	CFORCE 625 TOURING
	CF600ATR-2S	CF600ATR-2L
Overall Length	2035 mm	2235 mm
Overall Width	1180 mm	1180 mm
Overall Height	1220 mm	1390 mm
Wheel Base	1280 mm	1480 mm
Ground Clearance	270 mm	
Minimum Turning radius	3625 mm	3700 mm
Basic Weight	395 kg	400 kg
Front Rack Load Capacity	20 kg	
Rear Rack Load Capacity	40 kg	
Maximum Vehicle Load Allowed	135 kg	210 kg
Recommended Towing Capacities:		
Towing Hitch Weight	25 kg	
Trailer and Cargo Weight	300 kg	
Engine Model And Type	Single cylinder, liquid cooling, 4 stroke, SOHC, valves	
Type	191S	

## INTRODUCTION

Item	CFORCE 625	CFORCE 625 TOURING
	CF600ATR-2S	CF600ATR-2L
Bore × Stroke	91 mm × 89.2 mm	
Displacement	580 mL	
Compression Ratio	10.68 : 1	
Starting Type	ECU ignition	
Lubrication Type	Splash lubrication	
Engine Coolant: Type	Commercially available – Safe for aluminum engines	
Coolant Volume	2.3 qt ( 2.18 L )	
Mix Ratio	50% coolant / 50% distilled water	
Engine Oil: Type	SAE 15W-40 /SAE 10W-40 /SAE 5W-40	
Engine Oil Volume: Capacity Change / Oil Filter	2.96 qt ( 2.8 L )	

## INTRODUCTION

Item	CFORCE 625	CFORCE 625 TOURING
	CF600ATR-2S	CF600ATR-2L
Rear gear case Oil:		
Type	SAE 90W-GL-5	
Volume:	200 mL	
Periodic Oil Change	200 mL	
Front Gear Case Oil:		
Type	SAE 90W-GL-5	
Volume	230 mL	
Periodic Oil Change	230 mL	
Air Filter	Paper filter element with foam pre-filter	
Fuel Type	95(RON) or E10	
Fuel Tank Capacity	18 L	
Fuel Reserve Amount At Fuel Gauge 'Flash' (Approximate)	4 L	

## INTRODUCTION

Item		CFORCE 625	CFORCE 625 TOURING
		CF600ATR-2S	CF600ATR-2L
Spark Plug Type		DCPR8E/NGK	
Spark Plug Gap		0.8 mm ~ 0.9 mm	
Transmission	Transmission		CVT+gear shift
	Gear Shift/Order		Manual L/H/N/R/P
	CVT Ratio		0.67 ~ 3.02
	Gear Ratio	Low Gear	2.533
		High Gear	1.35
Reverse		2.071	
Chassis Frame	Steel tube		
Tires:			
Type		Tubeless	
Front		25×8.0-12	
Rear		25×10.0-12	

## INTRODUCTION

Item	CFORCE 625	CFORCE 625 TOURING
	CF600ATR-2S	CF600ATR-2L
Tire Pressure:		
Front	45 kPa	
Rear	45 kPa	
Brake System:	Front: hydraulic disc	
	Rear: hydraulic disc	
Foot Brake Type / Operation	Front/rear united brake Operated by right foot	
Hand Brake Type / Operation	Operated by right hand	
Parking Brake Type / Operation	Hydraulic parking brake Operated by both hand and foot	
Brake Fluid Type	DOT4	
Suspension:		
Front Suspension	Double A-arm and independent	
Rear Suspension	Double A-arm and independent	

## INTRODUCTION

Item	CFORCE 625	CFORCE 625 TOURING
	CF600ATR-2S	CF600ATR-2L
Shock Absorber:		
Front Shock Absorber	Hydraulic damping / oil damper	
Rear Shock Absorber	Hydraulic damping / oil damper	
Wheel Travel:		
Front Wheel Travel	160 mm	
Rear Wheel Travel	210 mm	
Electrical System:		
Ignition	ECU ignition	
Charging	A.C magneto	
Battery	12 Vdc / 30 Amp Hr	
Light System:		
Head Lamp, Low Beam	LED 14.4W×2	
Head Lamp, High Beam	LED 28.5W×4	
Front Position Light	LED 3.6W×2	
Tail Light/Brake Light	LED 2.9W×2 / LED 2W×2	
Dashboard	LED and LCD -- non-maintenance	

## OPERATOR SAFETY

# Operator Safety

### **⚠️ WARNING**

Failure to heed the warnings contained in this manual can result in serious injury or death. An Vehicle is not a toy and can be hazardous to operate. This vehicle handles differently from other vehicles, such as motorcycles and cars. A collision or rollover can occur quickly , even during routine maneuvers, like turning, or over obstacles, if you fail to take proper precautions.

Read this owner's manual. Understand all safety warnings, precautions and operating procedures before operating an Vehicle.

### **Age Restrictions**

This vehicle is an ADULT Vehicle ONLY. Operation is prohibited for anyone under the age of 16.

### **Know Your Vehicle**

As the operator of the vehicle, you are responsible for your personal safety, the safety of others, and the protection of our environment. Read and understand your owner's manual, which includes valuable information about all aspects of your vehicle, including safe operating procedures.

## **OPERATOR SAFETY**

### **Equipment Modifications**

We are concerned with the safety of our customers and for the general public. Therefore, we strongly recommend that consumers do not install on an Vehicle any equipment that may increase the speed or power of the vehicle, or make any other modifications to the vehicle for these purposes. Any modifications to the original equipment of the vehicle create a substantial safety hazard and increase the risk of body injury. The warranty on your Vehicle is terminated if any equipment has been added to the vehicle, or if any modifications have been made to the vehicle, that increase its speed or power.

### **NOTE**

The addition of certain accessories, including (but not limited to) mowers, blades, tires, sprayers, or large racks, may change the handling characteristics of the vehicle. Use only approved accessories, and familiarize yourself with their function and effect on the vehicle.

## OPERATOR SAFETY

### **Avoid Burns from Hot Parts**

Certain components become hot during operation. Avoid contact with those parts during and shortly after operation to avoid burns.

### **Pulling a Trailer**

Check the maximum axle loads of the vehicle identification plate (statutory plate). CFMOTO vehicle can tow a trailer on the road. Check the trailer, the maximum loads on the identification plate. Check the national packages limits the use of a vehicle-trailer on the road. Connect the trailer lights and set the slow moving vehicle triangle behind the trailer.

### **NOTE**

A CFMOTO approved rear hitch must be properly installed on the vehicle for hauling trailers. Riding this vehicle with a trailer substantially increases the risk of toppling, especially on inclined slopes. If a trailer is used behind the vehicle make sure that its hitch is compatible with the one on the vehicle. Make sure the trailer is horizontal with the vehicle. (In some instances a special extension may have to be installed on the vehicle hitch). Use security chains or cables to secure the trailer with the vehicle.

Reduce your speed when pulling a trailer and turn gradually. Avoid hills and rough terrain. Never attempt steep hills. Allow more distance for braking, especially on inclined surfaces and when a passenger is on board. Be careful not to skid or slide.

## OPERATOR SAFETY

### Safety Training

When you purchased your vehicle, your dealer offered a hands-on safety training course that covers all aspects of vehicle safety. You were also provided with printed materials that explain safe operating procedures. You should review this information on a regular basis. If you purchased a used Vehicle from a party other than a dealer, you can request safety training from any authorized dealer. Familiarize yourself with all laws and regulations concerning the operation of Vehicles in your area. CFMOTO strongly advises you to strictly follow the recommended maintenance program outlined in your owner's manual. This preventive maintenance program is designed to ensure that all critical components on your vehicle are thoroughly inspected and serviced at specific intervals for safety.

### Hazardous Operation Warnings

Serious injury or death can result if you do not follow the following instructions and procedures outlined in further detail within your owner's manual:

#### **WARNING**

- Never operate a vehicle without proper instruction.
- Never allow anyone under 16 years of age to operate this vehicle.
- Never permit a guest to operate the vehicle unless the guest has read this manual and all product labels and has completed a certified safety training course.
- Never operate an vehicle without wearing an approved helmet that fits properly. Always wear eye protection (goggles or face shield),gloves,boots,a long-sleeved shirt or jacket,and long pants.
- Never consume alcohol or drugs before or while operating a vehicle.

## OPERATOR SAFETY

- Never operate at excessive speeds. Travel at speeds appropriate for the terrain, visibility and operating conditions, and your experience.
- Never attempt wheelies, jumps or other stunts.
- Always inspect your vehicle before each use to make sure it's in safe operating condition.
- Always follow the inspection schedules and maintenance outlined in your owner's manual.
- Always keep both hands on the handlebars and both feet on the foot-rests of the Vehicle during operation.
- Always travel slowly and use extra caution when operating on unfamiliar terrain. Be alert to changing terrain conditions.
- Never operate on excessively rough, slippery, or loose terrain.
- Always follow proper turning procedures as described in this manual. Practice turning at low speeds before attempting to turn at faster speeds. Do not turn at excessive speeds.
- Always have the vehicle inspected by an authorized dealer if it's been involved in an accident.
- Never operate on hills too steep for the vehicle or for your abilities. Practice on smaller hills before attempting larger hills.
- Always follow proper procedures for climbing hills:
  - Check the terrain carefully before ascending a hill.
  - Never climb hills with excessively slippery or loose surfaces.
  - Shift your weight forward.
  - Never open the throttle suddenly or make sudden gear changes.
  - Never go over the top of a hill at high speed.

## **OPERATOR SAFETY**

- Always follow proper procedures for going downhill and for braking on hills:
  - Check the terrain carefully before you start down a hill.
  - Shift your weight backward.
  - Never go down a hill at high speed.
  - Avoid going down a hill at an angle, which would cause the vehicle to lean sharply to one side.
  - Travel straight down the hill when possible.
- Always follow proper procedures for crossing the side of a hill:
  - Avoid hills with excessively slippery or loose surfaces.
  - Shift your weight to the uphill side of the Vehicle.
  - Never attempt to turn the vehicle around on any hill until you've mastered (on level ground) the turning technique outlined in this manual.
  - Avoid crossing the side of a steep hill when possible.
- Always use proper procedures if you stall or roll backwards while climbing a hill:
  - To avoid stalling, maintain a steady speed when climbing a hill.
  - If you stall or roll backwards, follow the special procedure for braking described in this manual.
  - Always dismount on the uphill side, or to either side if the vehicle is pointed straight uphill.
  - Turn the Vehicle around and remount following the procedure described in this manual.
- Always check for obstacles before operating in a new area. Never attempt to operate over large obstacles, such as rocks or fallen trees. Always follow proper procedures when operating over obstacles as described in this manual.

## **OPERATOR SAFETY**

- Always be careful of skidding or sliding. On slippery surfaces like ice, travel slowly and use extra caution to reduce the chance of skidding or sliding out of control.
- Avoid operating the vehicle through deep or fast-flowing water. If it's unavoidable, travel slowly, balance your weight carefully, avoid sudden movements, and maintain a slow and steady forward motion. Do not make sudden turns or stops, and do not make sudden throttle changes.
- Wet brakes may have reduced stopping ability. Test your brakes after leaving water. If necessary, apply them lightly several times to allow friction to dry out the pads.
- Always check for obstacles or people behind the vehicle before operating in reverse. When it's safe to proceed in reverse, move slowly and avoid turning at sharp angles.
- Brake discs can be overheated after continuous braking. Allow brake disc to cool down before servicing.
- Always use the size and type of tires specified for your vehicle, and always maintain proper tire pressure.
- Never modify an vehicle through improper installation or use of accessories.
- Never exceed the stated load capacity for your vehicle. Cargo must be properly distributed and securely attached. Reduce speed and follow the instructions in this manual for carrying cargo or towing. Allow a greater distance for braking.
- Always remove the ignition key when the vehicle is not in use to prevent unauthorized use or accidental starting.
- Child or pets shall not be carried on the racks.
- Never touch running parts, such as wheels, drive shaft, etc.

**FOR MORE INFORMATION ABOUT Vehicle SAFETY, PLEASE CONTACT YOUR DEALER.**

## OPERATOR SAFETY

### **⚠WARNING**

#### **POTENTIAL HAZARD:**

Operating this Vehicle without proper instruction.

#### **WHAT CAN HAPPEN:**

The risk of an accident is greatly increased if the operator does not know how to operate the Vehicle properly in different situations and on different types of terrain.

#### **HOW TO AVOID THE HAZARD:**

Beginning and inexperienced operators should complete a certified training course offered by a dealer.

Operators should regularly practice the skills learned in the course and the operating techniques described in the owner's manual.

### **⚠WARNING**

#### **POTENTIAL HAZARD:**

Failure to follow the age recommendations for this vehicle.

#### **WHAT CAN HAPPEN:**

Severe injury and/or death could occur if a child under the minimum age recommendation operates an Vehicle. Even though a child may be within the recommended age group for operating some Vehicles, he/she may not have the skills, abilities or judgment needed to operate an Vehicle safely and could be susceptible to accident or injury.

#### **HOW TO AVOID THE HAZARD:**

Operation is prohibited for anyone under 16 years of age.

## OPERATOR SAFETY

### **⚠️ WARNING**

#### **POTENTIAL HAZARD:**

Carrying a passenger on an ATV that is not designed for carrying a passenger.

#### **WHAT CAN HAPPEN:**

A passenger riding on the ATV could be ejected from the vehicle unexpectedly or make contact with moving components, both of which can result in severe injury or death.

#### **HOW TO AVOID THE HAZARD:**

Never allow a passenger on an ATV that is not designed for carrying a passenger.

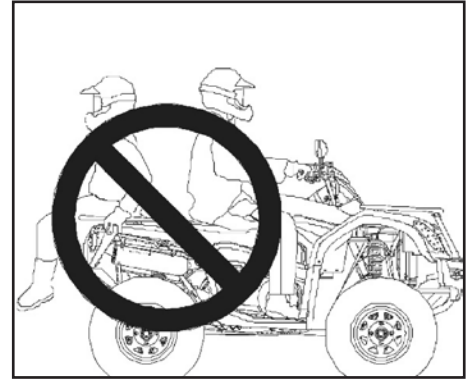

### **⚠️ WARNING**

#### **POTENTIAL HAZARD:**

Carrying more passengers than the rated passenger capacity.

#### **WHAT CAN HAPPEN:**

Carrying more passengers than the rated capacity greatly reduces the operator's ability to balance and control the ATV, which can result in severe injury or death.

#### **HOW TO AVOID THE HAZARD:**

Never allow more passengers than the rated passenger capacity.

## OPERATOR SAFETY

### **⚠️ WARNING**

#### **POTENTIAL HAZARD:**

Operating this Vehicle without wearing an approved helmet, eye protection and protective clothing.

#### **WHAT CAN HAPPEN**

Operating an Vehicle without an approved helmet increases the risk of a severe head injury or death in the event of an accident. Operating without eye protection could result in an accident and could increase the chance of a severe eye injury in the event of an accident.

#### **HOW TO AVOID THE HAZARD**

Always wear an approved helmet that fits properly.

Always wear eye protection (goggles or face shield), gloves, long-sleeved shirt or jacket, and long pants.

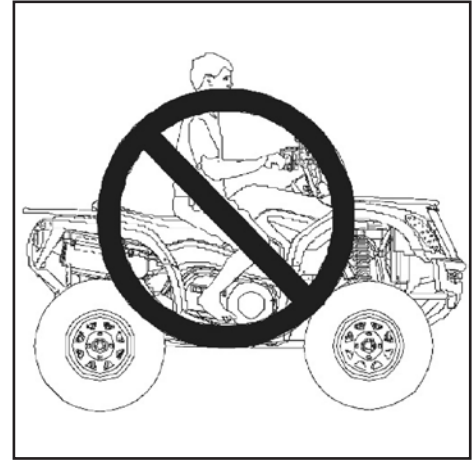

## OPERATOR SAFETY

### **⚠️ WARNING**

#### **POTENTIAL HAZARD:**

Operating the Vehicle after consuming alcohol or drugs.

#### **WHAT CAN HAPPEN**

Consumption of alcohol and/or drugs could seriously affect operator judgment. Reaction time may be slower and operator balance and perception could be affected.

Consumption of alcohol and/or drugs before or while operating an Vehicle could result in an accident causing severe injury or death.

#### **HOW TO AVOID THE HAZARD**

Never consume alcohol or drugs before or while operating an Vehicle.



## OPERATOR SAFETY

### **⚠️ WARNING**

#### **POTENTIAL HAZARD**

Operating the Vehicle at excessive speeds.

#### **WHAT CAN HAPPEN**

Excessive speed increase the operator's chance of losing control of the Vehicle, which can result in an accident.

#### **HOW TO AVOID THE HAZARD**

Always operate the Vehicle at a speed that is proper for the terrain, visibility and operating conditions, and your experience.

### **⚠️ WARNING**

#### **POTENTIAL HAZARD**

Attempting wheelies, jumps and other stunts.

#### **WHAT CAN HAPPEN**

Attempting stunts increases the chance of an accident, including an overturn.

#### **HOW TO AVOID THE HAZARD**

Never attempt wheelies, jumps, or other stunts. Avoid exhibition driving.

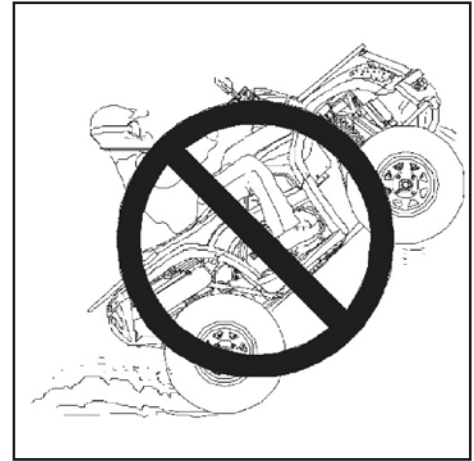

## OPERATOR SAFETY

### **⚠️ WARNING**

#### **POTENTIAL HAZARD**

Failure to inspect the Vehicle before operating. Failure to properly maintain the Vehicle.

#### **WHAT CAN HAPPEN**

Poor maintenance increases the possibility of an accident or equipment damage.

#### **HOW TO AVOID THE HAZARD**

Always inspect your Vehicle before each use to make sure it's in safe operating condition.

Always follow the inspection and maintenance procedures and schedules described in the owner's manual.

### **⚠️ WARNING**

#### **POTENTIAL HAZARD**

Removing hands from the handlebars or feet from the footrests during operation.

#### **WHAT CAN HAPPEN**

Removing even one hand or foot can reduce ability to control the vehicle or could cause loss of balance and ejection from the Vehicle.

If the operator's foot is not firmly planted on the footrest, it could come into contact with the rear wheels and lead to accident or injury.

#### **HOW TO AVOID THE HAZARD**

Always keep both hands on the handlebars and both feet on the footrests of the Vehicle during operation.

## OPERATOR SAFETY

### **⚠️ WARNING**

#### **POTENTIAL HAZARD**

Failure to use extra caution when operating the Vehicle on unfamiliar terrain.

#### **WHAT CAN HAPPEN**

Unfamiliar terrain may contain hidden rocks, bumps, or holes that could cause loss of control or overturn.

#### **HOW TO AVOID THE HAZARD**

Travel slowly and use extra caution when operating on unfamiliar terrain. Always be alert to changing terrain conditions.

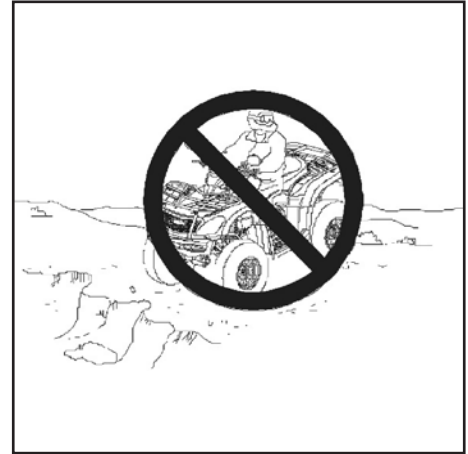

## OPERATOR SAFETY

### **⚠️ WARNING**

#### **POTENTIAL HAZARD**

Failure to use extra caution when operating on excessively rough, slippery or loose terrain.

#### **WHAT CAN HAPPEN**

Operating on excessively rough, slippery or loose terrain could cause loss of traction or loss of control, which could result in an accident or overturn.

#### **HOW TO AVOID THE HAZARD**

Do not operate on excessively rough, slippery or loose terrain until you've learned and practiced the skills necessary to control the Vehicle on such terrain. Always use extra caution on rough, slippery or loose terrain.



## OPERATOR SAFETY

### **⚠️ WARNING**

#### **POTENTIAL HAZARD**

Turning improperly.

#### **WHAT CAN HAPPEN**

Improper turns could cause loss of control and lead to a collision or overturn.

#### **HOW TO AVOID THE HAZARD**

Always follow proper procedures or turning as described in the owner's manual. Practise turning at slow speeds before attempting to turn at faster speeds.

Never turn at excessive speed.

## OPERATOR SAFETY

### **⚠️ WARNING**

### **POTENTIAL HAZARD**

Climbing excessively steep hills or climbing hills improperly.

### **WHAT CAN HAPPEN**

Improper hill climbing could cause loss of control or overturn.

### **HOW TO AVOID THE HAZARD**

Always follow proper procedures for climbing hills as described in the owner's manual. Never operate on hills too steep for the ATV or for your abilities. Practice on smaller hills before attempting large hills. Always check the terrain carefully before ascending any hill.

Never operate the Vehicle on hills steeper than 20°. Never climb hills with excessively slippery or loose surfaces. Shift your weight forward. Never open the throttle suddenly while traveling uphill.

The Vehicle could flip over backwards. Never go over the top of any hill at high speed. An obstacle, a sharp drop, or another vehicle or person could be on the other side of the hill.



## OPERATOR SAFETY

### **⚠️ WARNING**

#### **POTENTIAL HAZARD:**

Traveling down excessively steep hills.

#### **WHAT CAN HAPPEN:**

Improper downhill travel could cause loss of control or overturn.

#### **HOW TO AVOID THE HAZARD:**

Never operate on hills too steep for the ATV or for your abilities. Practice on smaller hills before attempting large hills. Always check the terrain carefully before attempting any hill. Never descend hills with excessively slippery or loose surfaces.

### **NOTE**

A special driving and braking technique is required while traveling downhill. Always check the terrain carefully before descending a hill. Shift your weight backward. Never travel down a hill at high speed. Avoid traveling down a hill at an angle, which would cause the vehicle to lean sharply to one side. Travel straight down the hill when possible.



## OPERATOR SAFETY

### **⚠️ WARNING**

#### **POTENTIAL HAZARD**

Improperly crossing hills and turning on hills.

#### **WHAT CAN HAPPEN**

Improperly crossing or turning on hills could cause loss of control or overturn.

#### **HOW TO AVOID THE HAZARD**

Never attempt to turn the Vehicle around on any hill until you've mastered the turning technique on level ground as described in the owner' s manual.

Use extra caution when turning on any hill. Avoid crossing the side of a steep hill.

#### **WHEN CROSSING THE SIDE OF A HILL:**

Always follow proper procedures as described in the owner' s manual. Avoid hills with excessively slippery or loose surfaces. Shift your weight to use uphill side of the Vehicle.



## OPERATOR SAFETY

### **⚠️ WARNING**

#### **POTENTIAL HAZARD**

Stalling, rolling backwards or improperly dismounting while climbing a hill.

#### **WHAT CAN HAPPEN**

The vehicle could overturn.

#### **HOW TO AVOID THE HAZARD**

Maintain steady speed when climbing a hill.

#### **IF ALL FORWARD SPEED IS LOST:**

Close the throttle. Keep your weight uphill. Apply the front brake. When fully stopped, apply the foot brake as well, then shift the gear selector to the park position.

#### **IF THE Vehicle BEGINS ROLLING:**

Keep weight uphill. Never apply engine power.

Never apply the foot brake while rolling backwards. Apply the front brake. When fully stopped, apply the foot brake and shift the gear selector to the parking position. Dismount on uphill side, or to either side if Vehicle is pointed straight uphill.

Turn the Vehicle around and remount, following the procedure described in the owner's manual.



## OPERATOR SAFETY

### **⚠️ WARNING**

#### **POTENTIAL HAZARD**

Improperly operating over obstacles.

#### **WHAT CAN HAPPEN**

Operating over obstacles could cause loss of control or overturn.

#### **HOW TO AVOID THE HAZARD**

Before operating in a new area, check for obstacles.

Avoid operating over large obstacles such as rocks and fallen trees when possible. If unavoidable, use extreme caution and always follow proper procedures as outlined in the owner's manual.

## OPERATOR SAFETY

### **⚠ WARNING**

#### **POTENTIAL HAZARD**

Skidding or sliding.

#### **WHAT CAN HAPPEN**

Skidding or sliding can cause loss of control. If the tires regain traction unexpectedly, the Vehicle could overturn.

#### **HOW TO AVOID THE HAZARD**

On slippery surface such as ice, travel slowly and use extra caution to reduce the chance of skidding or sliding out of control.

### **⚠ WARNING**

#### **POTENTIAL HAZARD**

Overloading the Vehicle or carrying/towing cargo improperly.

#### **WHAT CAN HAPPEN**

Overloading and towing can cause changes in vehicle handling, which could lead to loss of control or an accident.

#### **HOW TO AVOID THE HAZARD**

Never exceed the stated load capacity for this Vehicle.

Cargo should be properly distributed and securely attached. Reduce speed when carrying cargo or pulling a trailer. Allow a greater distance for braking. Always follow the instructions in the owner's manual for carrying cargo or pulling a trailer.

## OPERATOR SAFETY

### **⚠ WARNING**

#### **POTENTIAL HAZARD**

Operation the Vehicle through deep or fasten-following water.

#### **WHAT CAN HAPPEN**

The tires may float, causing loss of traction and loss of control, which lead to an accident or overturn.

#### **HOW TO AVOID THE HAZARD**

Avoid operating the Vehicle through deep or fast-flowing water. If it is unavoidable to enter water that exceeds the recommended maximum depth, travel slowly, balance your weight carefully, avoid sudden movements, and maintain a slow and steady forward motion. Do not make sudden turns or stops, and do not make sudden throttle changes. Wet brakes may have reduced stopping ability. Always test the brakes after leaving the water. If necessary, apply brakes several times to dry out the pads.

## OPERATOR SAFETY

### **⚠ WARNING**

#### **POTENTIAL HAZARD**

Improperly operating in reverse.

#### **WHAT CAN HAPPEN**

The Vehicle could collide with an obstacle or person, resulting in severe injury.

#### **HOW TO AVOID THE HAZARD**

Before shifting into reverse gear, always check for obstacles or people behind the Vehicle. When it's safe to proceed, back slowly.

### **⚠ WARNING**

#### **POTENTIAL HAZARD**

Operating this Vehicle with improper tires, or with improper or uneven tire pressure.

#### **WHAT CAN HAPPEN**

Use of improper tires, or operation of the Vehicle with improper or uneven tire pressure, could cause loss of control or accident.

#### **HOW TO AVOID THE HAZARD**

Always use the size and type of tires specified in the owner's manual for the Vehicle. Always maintain proper tire pressure.

## OPERATOR SAFETY

### **⚠ WARNING**

#### **POTENTIAL HAZARD**

Operating the Vehicle with improper modifications.

#### **WHAT CAN HAPPEN**

Improper installation of accessories or modification of the Vehicle may cause changes in handling which could lead to an accident.

#### **HOW TO AVOID THE HAZARD**

Never modify the Vehicle through improper installation or use of accessories. All parts and accessories added to the vehicle must be genuine parts or equivalent components designed for use on this Vehicle and should be installed and used according to approved instructions. Consult your dealer for more information.

### **⚠ WARNING**

#### **POTENTIAL HAZARD**

Operating on frozen bodies of water.

#### **WHAT CAN HAPPEN**

Severe injury or death can result if the Vehicle and or the operator fall through the ice.

#### **HOW TO AVOID THE HAZARD**

Never operate the Vehicle on a frozen body of water.

## OPERATOR SAFETY

### **⚠ WARNING**

#### **POTENTIAL HAZARD**

Improper dismantling and disposal of hazardous materials.

#### **WHAT CAN HAPPEN**

It could damage the environment.

#### **HOW TO AVOID THE HAZARD**

**ALWAYS BE ENVIRONMENTALLY RESPONSIBLE**

Follow the guidelines of the governmental agency for the proper disposal of hazardous materials such as engine oil, fuel, engine coolant and machine fluid, grease. Never disposal of hazardous materials irresponsibly by dumping them into a sewer, on the ground, or into groundwater or waterways. Failure to follow these procedures may seriously harm the environment. Comply with legal regulations and guidelines for disposal of: empty containers for fuel, cooling water (coolant), oil, grease; fuel/oil filters; battery; machine itself; machine accessories; and packaging materials.

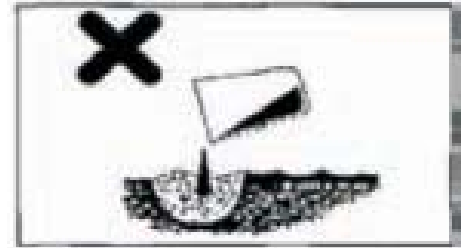

## OPERATOR SAFETY

### **⚠️ WARNING**

Leaving the keys in the ignition can lead to unauthorized use of the vehicle, resulting in serious injury or death. Always remove the ignition key when the vehicle is not in use.

### **⚠️ WARNING**

After any overturn or accident, have a qualified service dealer inspect the entire vehicle for possible damage, including (but not limited to) brakes, throttle and steering systems.

### **⚠️ WARNING**

Safe operation of this rider-active vehicle requires good judgment and physical skills.

Persons with cognitive or physical disabilities who operate this vehicle have an increased risk of overturn and loss of control, which could result in severe injury or death.

### **⚠️ WARNING**

Exhaust system components are very hot during and after use of the vehicle. Hot components can cause serious burns and fire. Do not touch hot exhaust system components. Always keep combustible materials away from the exhaust system. Use caution when traveling through tall grass, especially dry grass.

## OPERATOR SAFETY

### Safe Riding Gear

Always wear clothing suited to the type of riding. Vehicle riding requires special protective clothing for comfort and to reduce the chance of injury.

#### 1 . Helmet

Your helmet is the most important piece of protective gear for safe riding. An approved helmet can prevent a severe head injury.

#### 2 . Eye protection

Do not depend on sunglasses for proper eye protection. A pair of goggles or a helmet face shield offers the best protection for your eyes. They should be kept clean and be shatterproof design.

#### 3 . Gloves

Off- road style gloves with knuckle pads are the best for comfort and protection.

#### 4 . Boots

The best footwear is a pair of strong over- the- calf boots with heels, like motocross boots.

#### 5 . Clothing

Always wear long sleeves and long pants to protect arms and legs. Riding pants with kneepads and a jersey with shoulder pads provide the best protection.

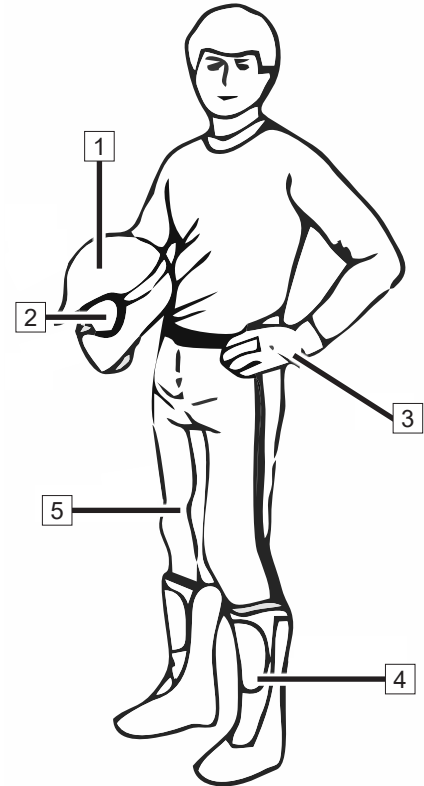

## SAFETY DECALS & LOCATIONS

### Safety Decals and Locations

Warning decals have been placed on the Vehicle for your protection. Read and follow the instruction on each decal carefully. If a decal becomes illegible or comes off, contact your dealer to purchase a replacement.

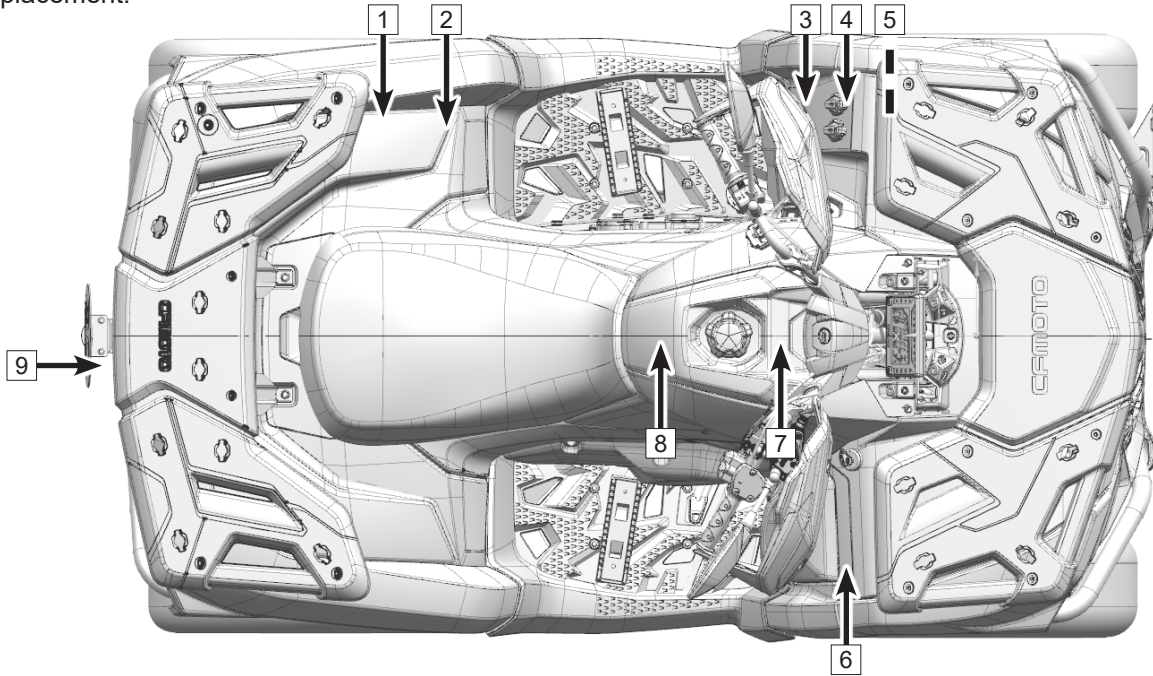

## SAFETY DECALS & LOCATIONS

1

TYPE I

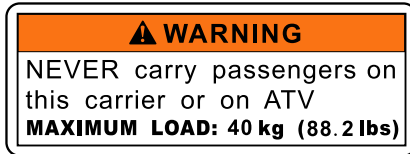

TYPE II



2

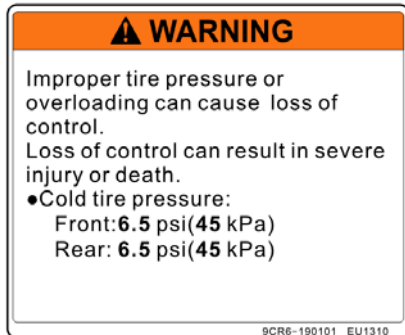

## SAFETY DECALS & LOCATIONS

TYPE I

TYPE II

3

**⚠ WARNING**

Improper ATV use can result in SEVERE INJURY or DEATH.



ALWAYS USE AN APPROVED HELMET AND PROTECTIVE GEAR

NEVER CARRY PASSENGERS

NEVER USE WITH DRUGS OR ALCOHOL

**NEVER** operate :

- without proper training or instruction.
- at speeds too fast for your skills or the conditions.
- with a passenger-passengers affect balance and steering and increase risk of losing control.

**ALWAYS :**

- use proper riding techniques to avoid vehicle overturns on hills and rough terrain and in turns.
- avoid paved surfaces-pavement may seriously affect handling and control.

LOCATE AND READ OWNER'S MANUAL... FOLLOW ALL INSTRUCTIONS AND WARNINGS.

9GQ0-190102 EU151

**⚠ WARNING**

Improper ATV use can result in SEVERE INJURY or DEATH.



ALWAYS USE AN APPROVED HELMET AND PROTECTIVE GEAR

NEVER USE WITH DRUGS OR ALCOHOL

**NEVER** operate :

- without proper training or instruction.
- at speeds too fast for your skills or the conditions.

**ALWAYS :**

- use proper riding techniques to avoid vehicle overturns on hills and rough terrain and in turns.
- avoid paved surfaces-pavement may seriously affect handling and control.

LOCATE AND READ OWNER'S MANUAL... FOLLOW ALL INSTRUCTIONS AND WARNINGS.

## SAFETY DECALS & LOCATIONS

3

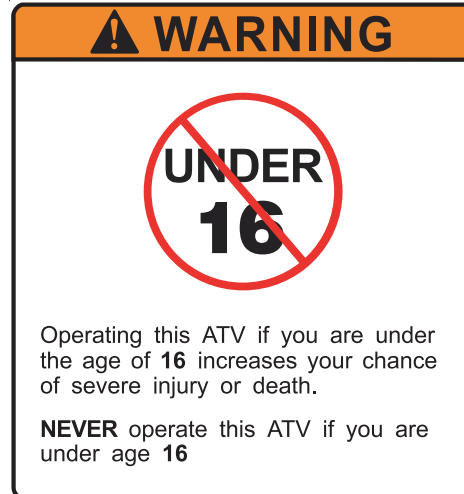

## FEATURES & CONTROLS

4

**DRIVE SELECT LEVER**

- Read owner's manual carefully before operating.
- Always stop the ATV and press the foot brake pedal before shifting the transmission.

9010-190013-1 US184

5

TYPE I

**⚠ WARNING**

NEVER carry passengers on this carrier or on ATV  
**MAXIMUM LOAD: 20 kg (44.1lbs)**

TYPE II

**⚠ WARNING**

NEVER carry passengers on this carrier  
**MAXIMUM LOAD: 20 kg (44.1lbs)**

## FEATURES & CONTROLS

6

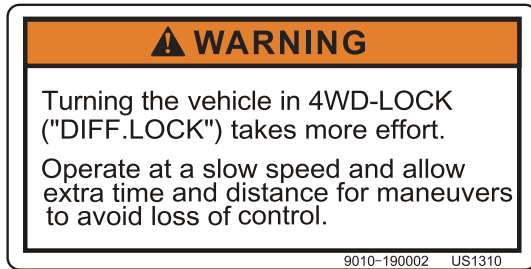

7



## FEATURES & CONTROLS

8



9

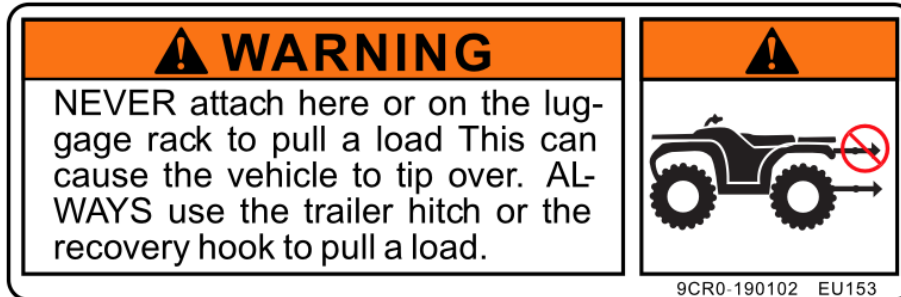

## FEATURES & CONTROLS

### Features and Controls Left Hand Controls

#### 1 Hazard Switch

Press the button . Front turn lights, rear turn lights and turn signal indicators on dashboard flash.

#### 2 Engine Stop Switch

When the switch is at  position, the engine shuts off.

When the switch is at  position, the engine can be started.

#### 3 Horn Button

 Press the button, the horn will sound.

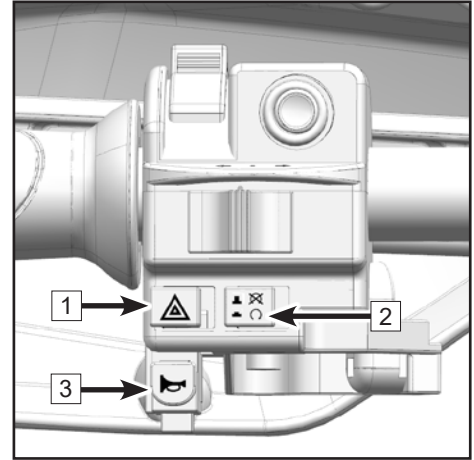

## FEATURES & CONTROLS

### 4 Headlight Switch

The headlight switch consists of 4 positions:

: When the switch is at this position, Hi beam, front position light, tail light, and license plate light are on.

: When the switch is at this position, Lo beam, front position light, tail light, and license plate light are on.

OFF: When the switch is at this position, all lights are off.

: When the switch is at this position, tail light, license plate light, and front position light are on.

#### CAUTION

Do not use the headlights with the engine turned off for more than 15 minutes. The battery may discharge to the point that the starter motor will not operate properly. If this should happen, remove the battery and recharge it.

### 5 Starter Switch

When the main switch is turned to ON, and the engine stop switch is at , push this button to start the engine.

### 6 Turn Switch (If equipped)

Move the switch to  for left turn signal indicator on.

Move the switch to  for right turn signal indicator on.

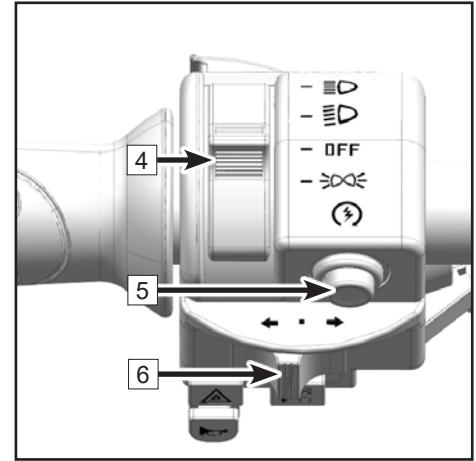

## FEATURES & CONTROLS

### 7 Override Button

The engine is normally limited when operating in 4WD-LOCK. If conditions require more engine power in 4WD-LOCK:

- Release the throttle and press the button to override the speed limiting function. While this button is depressed, the override indicator light will come on.
- Releasing the button restores the speed limiting function.

#### **⚠ WARNING**

Pressing the override button while the throttle is open can cause loss of control, resulting in severe injury or death. Always release the throttle before pressing the override button.

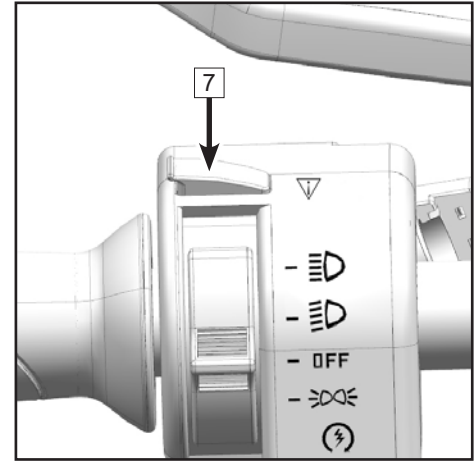

## FEATURES & CONTROLS

### 8 Parking brake lever

A mechanical parking brake is mounted to the right handlebar control. To activate the parking brake, flip the lever to the right, which also prevents the throttle from being applied while the parking brake is activated.

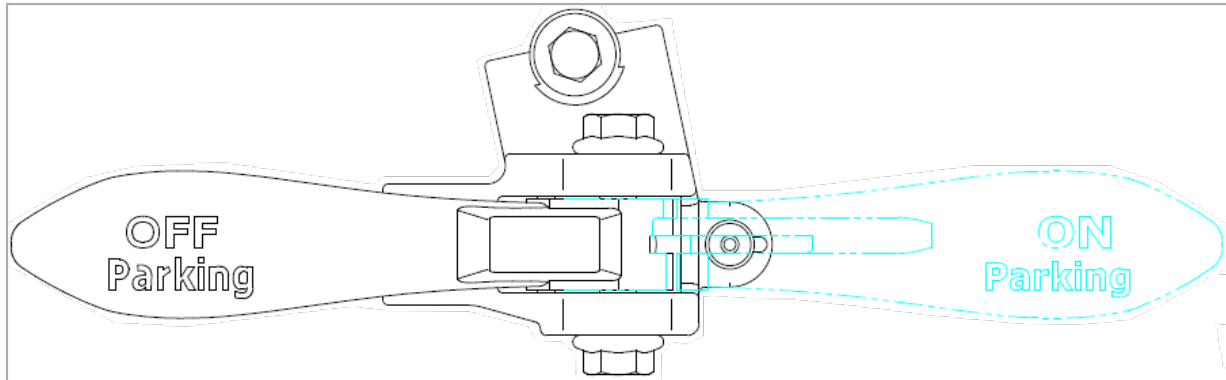

## FEATURES & CONTROLS

### Right Hand Controls

#### 1 Front Brake

The front brake lever **1** is located on the right handlebar and controls only the front brakes. Pull it toward the handlebar to apply the front brake. When squeezed, the lever should feel firm. Any sponginess would indicate a possible fluid leak or low master cylinder fluid level, which must be corrected before riding. Contact your dealer for proper diagnosis and repairs.

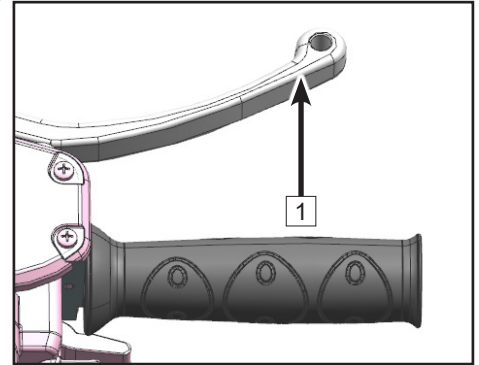

#### 2 Front Brake Fluid Reservoir and Level Indicator

Check the fluid level in the front brake fluid reservoir before each use of the ATV. The front brake fluid reservoir is located on the right handlebar. The fluid level can be viewed through the indicator window on the side of the master cylinder. If the fluid level is lower than the “lower” mark, refill with brake fluid as necessary.

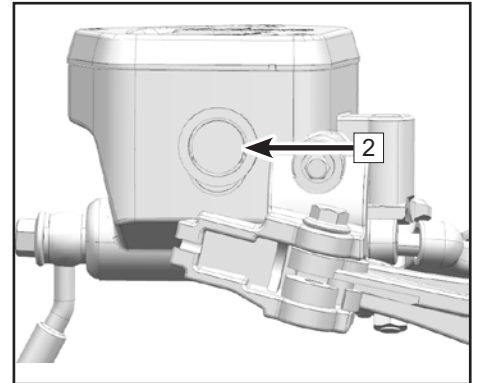



#### **⚠ WARNING**

An over-full master cylinder may cause brake drag or brake lock-up, which could result in serious injury or death. Maintain brake fluid at the recommended level. Do not overfill.

## FEATURES & CONTROLS

### 3 Four Wheel Drive (4WD) System Switch

This ATV is equipped with on-command “2WD”/“4WD” and “LOCK”/“4WD” switches:

- Two-wheel drive (2WD)  : Power is supplied to the rear wheels only. The mode lever **A** is moved to the left and the switch button is outward.
- Four-wheel drive (4WD)  : Power is supplied to the rear and front wheels. The mode lever **A** is moved to the left and the switch button is pushed in.
- Four-wheel drive LOCK (4WD-LOCK)  : Power is supplied to the rear and front wheels. The mode lever **A** is moved to the right and the switch button is pushed in. The front differential is locked, so all wheels turn at the same speed.

#### NOTE - 4WD-LOCK MODE

- When the mode switch is set to “F-LOCK”, the indicator light will flash until the front differential is locked.
- If the indicator light is flashing, turning the handlebar left and right will help the front differential lock engage.
- Riding before the front differential is properly engaged (e.g., when the indicator light is flashing) will cause the engine speed to be limited until engagement is complete.
- When the ATV is in 4WD-LOCK, the maximum traveling speed is limited to 30 km/h (19 mph). If conditions require full engine power to be available, press the override switch to disable the 4WD-LOCK speed limiter.

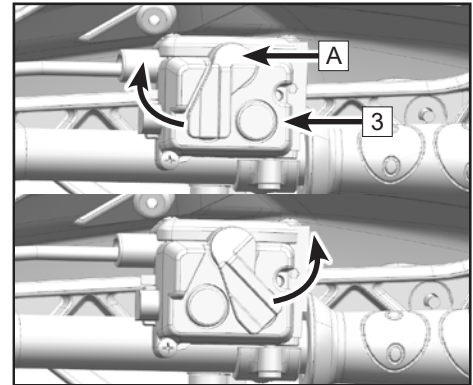

## FEATURES & CONTROLS

### 4 Throttle Lever

Once the engine is running, movement of the throttle lever will increase the engine speed. Regulate the speed of the machine by varying the throttle position. Because the throttle is spring loaded, the machine will decelerate, and the engine will return to an idle any time the hand is removed from the throttle lever. Before starting the engine, check the throttle to be sure it is operating smoothly. Make sure it returns to the idle position as soon as the lever is released.

#### CAUTION

Check the operation of the throttle lever before you start the engine. If it does not work smoothly, check for the cause. Correct the problem before riding the ATV. Consult your dealer if you can't find or solve the problem.

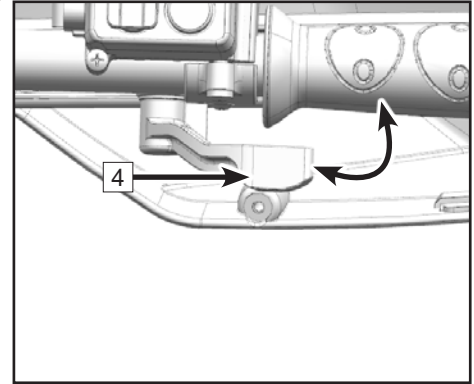

## FEATURES & CONTROLS

### 5 Parking Brake

Parking brake is mounted on the right hand brake. shift the parking brake lever **B** to the right side. When the parking brake is applied, it will stop.

#### CAUTION

Do not to rely only on the parking brake when parked on an incline. For additional safety, shift the transmission to the park position and block the wheels to prevent vehicle rolling.

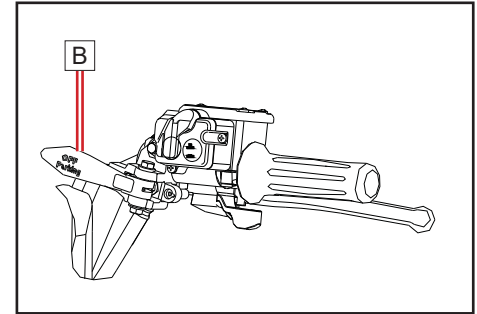

## FEATURES & CONTROLS

### 6 Mechanical Speed Limiter

A mechanical speed limiter keeps the throttle from fully opening, even when the throttle lever is pushed to maximum travel. Turning in the screw limits the throttle lever travel, which reduces the maximum engine power available and decreases the maximum speed of the ATV.

#### NOTE

Your ATV is set for maximum throttle opening from the factory.

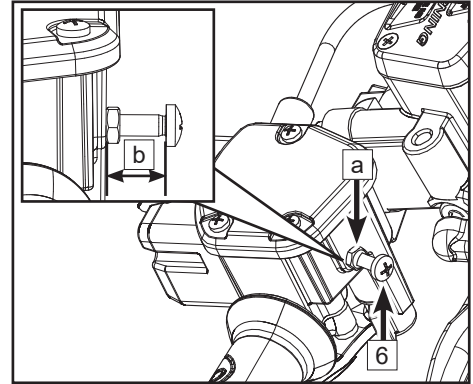

#### ⚠ CAUTION

Always loosen the locking nut **a** before each adjustment. Do not turn the adjusting screw out more than **b** 12 mm (0.47 in). Always make sure the throttle lever free play remains adjusted to 3 mm ~ 5 mm (0.12 in ~ 0.20 in). Tighten the locking nut when the adjustment is completed.

## FEATURES & CONTROLS

### Foot Controls

#### 1 Foot Brake

The foot brake pedal **1** is located on the right side floor board of the vehicle. Pushing down on the pedal applies the front and rear brakes at the same time.

When applied, the pedal should feel firm. A soft brake pedal would indicate a possible fluid leak or low master cylinder fluid level, which must be corrected before riding. Contact your dealer for proper diagnosis and repairs.

#### **⚠ WARNING**

Operating the ATV with a spongy brake lever or pedal can result in loss of control, which could cause an accident. Never operate with a spongy-feeling brake lever or pedal.

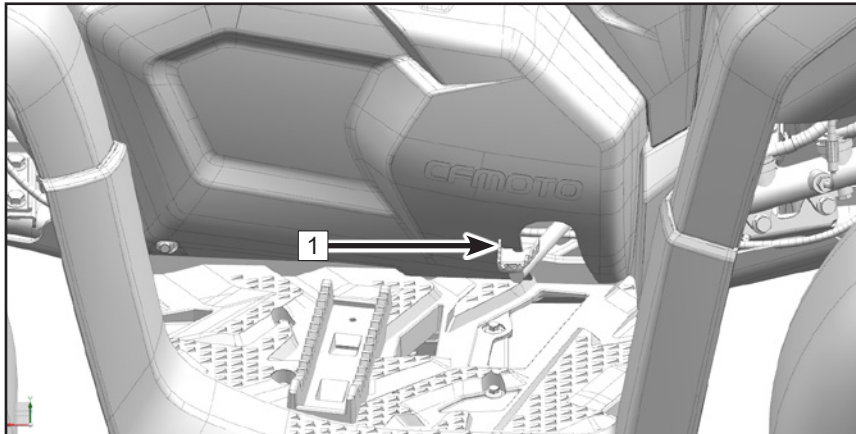

## FEATURES & CONTROLS

### 2 Foot Brake Reservoir Fluid Level Check

#### NOTE

Remove the front access cover and then check the fluid level.

When checking the fluid level, the ATV must be on level ground. If fluid level is lower than the “lower” mark **A**, add DOT4 brake fluid. Don’t overfill.

#### **⚠ WARNING**

Never store or use a partial bottle of brake fluid. Brake fluid is hygroscopic, meaning it rapidly absorbs moisture from the air. The moisture causes the drop of boiling temperature of the brake fluid, which can lead to early brake fade and the possibility of accident or severe injury. After opening a bottle of brake fluid, always discard any unused portion.

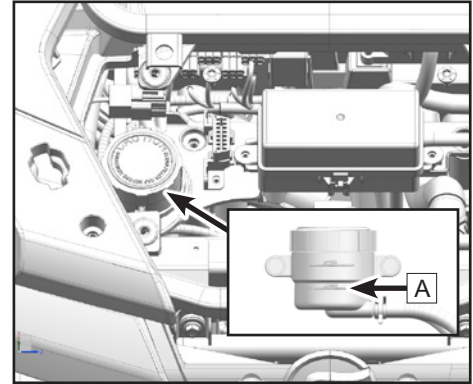



## FEATURES & CONTROLS

### Vehicle Features

#### 1 Main Switch

Functions of the respective switch positions are as follows:

 :The engine can be started only at this position and the headlights and taillight come on when the light switch is on. The key can not be removed in this position.

 :All electrical circuits are switched off. The key can be removed in this position.

The 'P' position has no function.

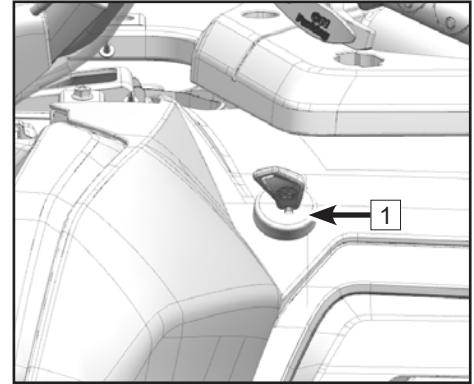

#### NOTE

Remove and store the spare key in a safe place. Your key can be duplicated only by mating a key blank with one of your existing keys. If both keys are lost, the complete switch assembly must be replaced.

## FEATURES & CONTROLS

### Power Socket and USB Outlet 2

Auxiliary 12Vdc power and USB outlets are provided on the left side front fender area for operating accessories such as hand held spot lights and charging electronic devices. Please consult with your dealer on the use of powered accessories with your vehicle.

### 3 Fuel Tank

The fuel tank fill cap is located at the top of the vehicle behind the handlebars. Cap removal is left-handed rotation. Cap installation is right-handed rotation.

### Fuel Minimum Octane Rating

The recommended fuel for your Vehicle is minimum 95 Octane unleaded. Non-oxygenated (ethanol-free) fuel is recommended for best performance in all conditions.

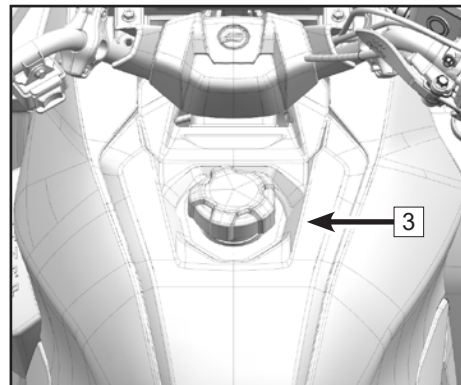
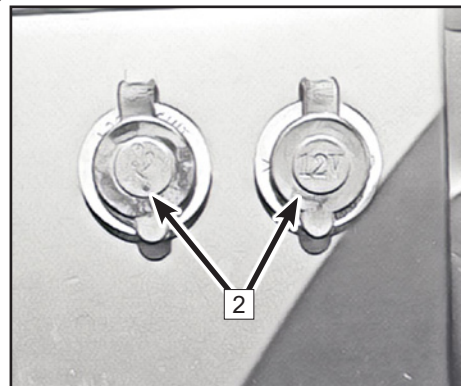

## FEATURES & CONTROLS

### Front Storage Box / Rear Storage Box

This vehicle is equipped with storage boxes on the front right side and the rear position.

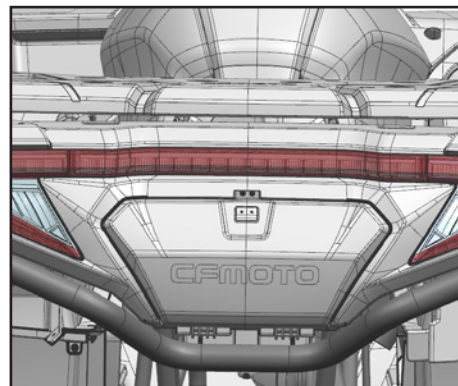
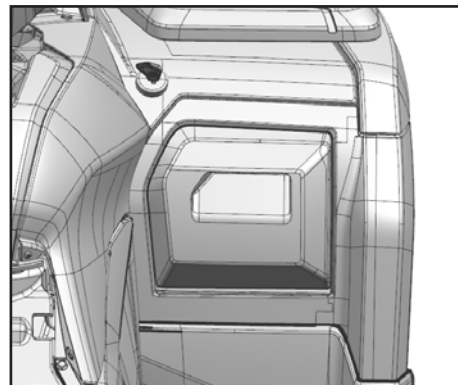

## FEATURES & CONTROLS

### Fuel safety

#### **WARNING**

Gasoline is highly flammable and explosive under certain conditions.

- Always exercise extreme caution whenever handling gasoline.
- Always refuel with the engine stopped, and outdoors or in a well ventilated area.
- Never carry a plastic container with gasoline in the racks while riding. Static electricity between the rack and container could cause a spark.
- Do not smoke or allow open flames or sparks in or near the area where refueling is performed or where gasoline is stored.
- Do not overfill the tank. Do not fill the tank neck.
- If gasoline spills on your skin or clothing, immediately wash it off with soap and water and change clothing.
- Never start the engine or let it run in an enclosed area. Engine exhaust fumes are poisonous and can cause loss of consciousness or death in a short time.

#### **WARNING**

The engine exhaust from this product contains chemicals known to cause cancer, birth defects or other reproductive harm. Operate this vehicle only outdoors or in well-ventilated areas.

## FEATURES & CONTROLS

### 4 Transmission Gear Selector

The transmission gear selector is located on the left side of the vehicle:

#### **Gear Pattern**

L – Low Gear

H – High Gear

R – Reverse Gear

P – Park

Selector Direction

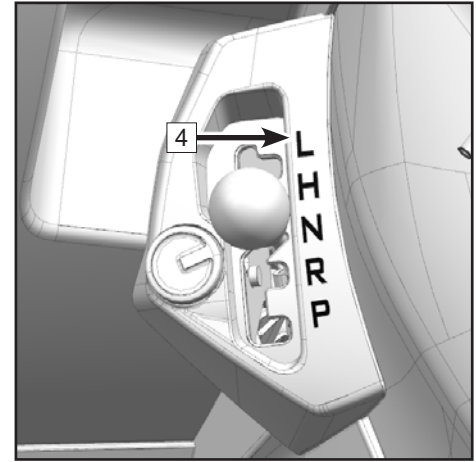

#### **⚠ CAUTION**

Always stop the ATV and press the foot brake pedal before shifting the transmission.

When operating under L gear, the maximum speed is limited at 30 km/h.

## FEATURES & CONTROLS

### 5 Parking

When parking, stop the engine and shift the gear selector Lever into the park position.

#### **⚠ CAUTION:**

When shifting the transmission in PARK, always push the brake pedal.

Shake the vehicle forward and backward to check if the parking brake is engaged.

#### **⚠ WARNING**

Never depend on the parking brake alone if the vehicle is parked on a hill. Always block the wheels on the downhill side of the vehicle to prevent rolling. It's recommended to park the vehicle on a level ground.

### **Gear selector lock**

Gear selector lock [6] is used for locking the transmission to prevent the vehicle from theft.

When the vehicle needs to be left for long time or stopped outside, shift the gear selector [5] in P gear and lock the transmission by the gear selector lock [6] to prevent theft.

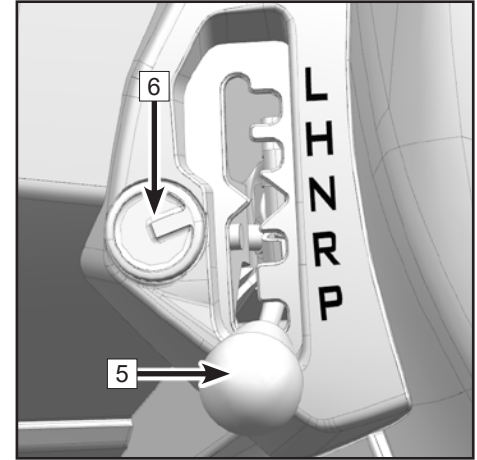

## FEATURES & CONTROLS

### **Towing**

This vehicle is equipped with a hitch receiver for towing trailers. Please consult with your dealer about towing, the use of trailers, and available accessories for connecting a trailer to the vehicle.

### **Winch**

This vehicle is equipped with a winch. The winch control is located on the left handle bar. To preserve battery power, only operate the winch when the engine is running. Please consult with your dealer on the use of the winch before using your vehicle.

## FEATURES & CONTROLS

### GENERAL SAFETY PRECAUTIONS REGARDING THE USE OF WINCH

#### **WARNING**

##### **Moving Part Hazards**

##### **To prevent serious injury and property damage:**

- Do not operate or install winch without reading and understanding these instructions and the Basic Guide to Winching Techniques.
- Keep hands clear of wire rope, hook and fairlead opening during operation and when spooling.
- Use supplied hook strap for spooling wire rope.
- Stand clear of wire rope and load during operation.
- Keep others away.
- Inspect winch installation and wire rope condition before operating winch
- Do not use as a hoist.
- Do not use to move persons.
- Do not exceed winch's rated capacity.
- Never touch wire rope or hook while in tension.
- Be certain the anchor you select will withstand load.
- Never wrap wire rope back onto itself. Use a choker chain or tree trunk protector on the anchor.

- Prior to initiating winching operation be sure any element which can interfere with safe winching is removed.
- Do not disengage clutch if winch is under load or wire rope is in tension.
- Take your time. Sloppy rigging causes accidents.
- The wire rope must always spool onto the drum as indicated by the drum rotation label on the winch.

#### **CAUTION**

##### **To avoid injury and property damage:**

- Do not use winch to secure a load during transport.
- Do not submerge in water.
- Do not use to tow other vehicles.
- Wear heavy leather gloves when handling the wire rope.
- Never winch with less than 5 wraps of wire rope around the drum.
- Caution should be used if the vehicle is tied down during a winching operation. This may lead to damage to the frame.
- Before winching, inspect remote control lead for damage.

## FEATURES & CONTROLS

### Front panel access

Your vehicle is equipped with an access panel on the front rack.

#### To remove the panel:

1. Lift and pull the rubber retaining strap away from the panel until the strap releases from the front tab.
2. Lift up on the nose of the panel. Slide the panel upward toward you and away from the rack.

#### To reinstall the panel:

1. Align the tabs at the rear of the cover into the rack and place the cover into the rack opening.
2. Press down on the center of the cover.
3. Lift and push the rubber retaining strap onto the front panel tab to secure it.

### Rear storage

Your vehicle is equipped with a storage compartment at the rear of the vehicle.

#### To open:

1. Lift and pull the rubber retaining strap away from the cover until the strap releases from the tab.
2. Pull the cover toward you.

#### To close:

1. Secure the cover onto the opening.
2. Press on the center of the cover.
3. Lift and pull the rubber retaining strap onto the cover tab to secure it.

## FEATURES & CONTROLS

### Alarm

This vehicle is configured with an alarm that performs the following functions:

- When oil pressure signal is in GND, and RPM  $\geq 1000$  r/min, alarm sounds one short/time. When the oil pressure rises to the normal range, the alarm disappears.
- If water temperature is  $> 120^{\circ}\text{C}$ , alarm sounds two short/time. When the water temperature returns to the normal range, the alarm disappears.
- When engine speed is  $\geq 8000$  rpm, alarm sounds three short/time. When the engine speed returns to the normal range, the alarm disappears.

## FEATURES & CONTROLS

### CVT System

This vehicle has a Continuously Variable Transmission (CVT) system that utilizes a belt and clutch pulleys to automatically vary transmission ratios, allowing infinite variability between the highest and lowest vehicle speeds with no discrete steps or shifts.

The CVT consists of a primary clutch [1], which is an advanced form of centrifugal clutch that is mounted to the engine crankshaft [A]. The primary clutch also contains a one-way bearing that creates an engine braking feature to slow the vehicle without having to use the hand or foot brake.

The secondary clutch [2] is mounted to the input shaft of the transmission [B] and serves two functions: As a “slave” pulley to the primary clutch, and to provide a torque sensing element. The drive belt [3] is a heavy duty V-belt that connects the engine and transmission pulleys.

A CVT housing and cover encloses the clutches and belt assembly. It has inlet and outlet cooling ducts that route air to cool the components, and they should be inspected. The CVT components do not contain any user maintenance items. Contact your dealer for service.

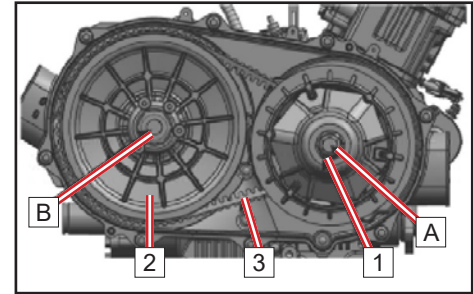

## FEATURES & CONTROLS

### How To Avoid CVT Drive Belt and Component Failure

CVT clutch and belt life can be dramatically extended by avoiding these common operating mistakes:

<b>Causes CVT damage:</b>	<b>Solution:</b>
Attempting to load the vehicle onto a truck bed or tall trailer in high gear.	Shift transmission to low gear during loading of the vehicle to prevent belt burning.
Starting out on a steep incline in high gear.	When starting out on steep inclines, use low gear.
Constant driving in high gear at low RPM, driving at just above clutch engagement RPM, or at low speed (approximately 3mph~6mph [5km/h~10 km/h]).	Low gear is highly recommended for cooler CVT operating temperatures and longer component life. Drive at a higher speed or use low gear more frequently.
Insufficient warm-up of CVT exposed to low ambient temperatures	Warm the engine before driving, the CVT drive belt will become more flexible and prevent belt burning.
Slow throttle and easy CVT engagement.	Use the throttle with purpose and effectively for efficient CVT clutch engagement.
Towing/pushing at low RPM/low ground speed.	Use low gear only.
Utility use/plowing snow, dirt, etc.	Use low gear only.
Heavy vehicle load operating at low speed	Use low gear only.

## FEATURES & CONTROLS

<b>Causes CVT damage:</b>	<b>Solution:</b>
Climbing over large objects from a stopped position.	Shift the transmission to low gear, and carefully use fast, brief, aggressive throttle application to engage the CVT. <b>WARNING:</b> Excessive throttle may cause loss of control and vehicle overturn.
Climbing over large objects from a stopped position.	Shift the transmission to low gear, and carefully use fast, brief, aggressive throttle application to engage the CVT. <b>WARNING:</b> Excessive throttle may cause loss of control and vehicle overturn.
Belt slipping from water or snow ingestion into the CVT system.	Drain the water from the CVT housing and dry the CVT if possible, or contact your dealer.
Overheating of the CVT components causes malfunction.	Contact your dealer for inspection and repair of the CVT components.

# FEATURES & CONTROLS

## Dashboard Indicators and Warnings

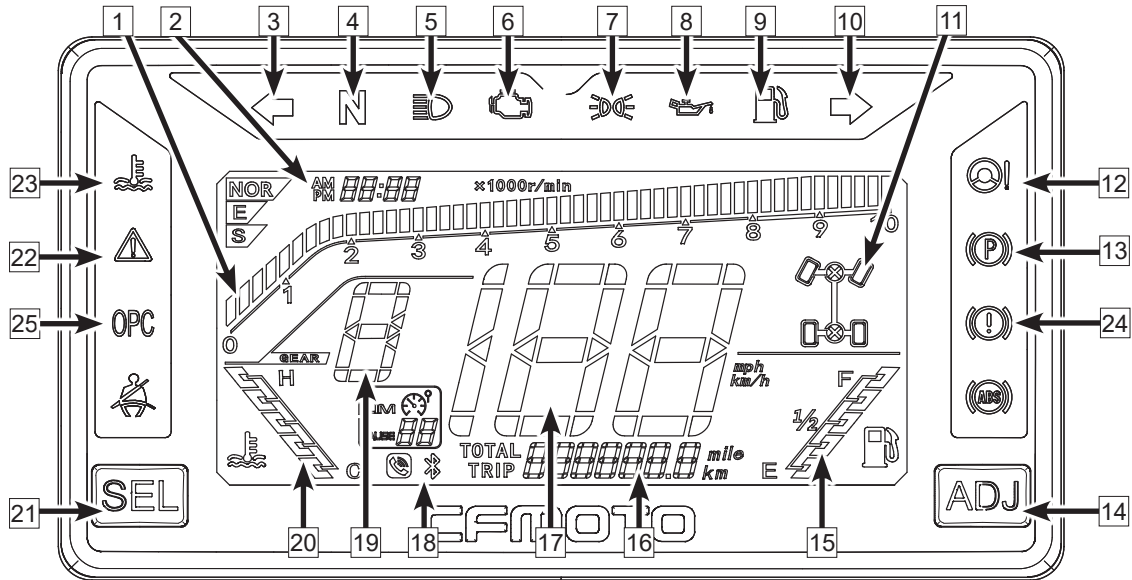

## FEATURES & CONTROLS

1	Engine RPM	10	Turning light, RH	19	Gear position indicator
2	Clock	11	Drive mode	20	Coolant Temperature
3	Turning light, LH	12	EPS indicator	21	SEL - mode select button
4	Neutral indicator	13	Parking brake indicator	22	Override indicator
5	High beam indicator	14	ADJ - mode adjust button	23	Coolant Temperature Warning indicator
6	EFI fault indicator	15	Fuel gauge	24	Brake fault warning indicator
7	Position light indicator	16	Odometer	25	OPC indicator
8	Oil pressure indicator	17	Speedometer		
9	Low fuel indicator	18	Bluetooth indicator		

### Engine RPM - 1

Indicate the engine current RPM, keep the RPM away from the red area.

### Clock - 2

Display the current time. (This dashboard section can be adjusted to correct time by using the “ADJ” and “SEL” button.)

### Turning light, LH - 3

When switch turns to left turning light position, the indicator is on.

## FEATURES & CONTROLS

### **Neutral indicator - 4**

This indicator displays when the transmission is in neutral.

### **High beam indicator - 5**

This indicator illuminates when the headlight switch turns to high beam position.

### **EFI fault indicator - 6**

This indicator displays when a fault occurs in the Electronic Fuel Injection system. Please stop the vehicle and contact your dealer to eliminate the fault.

### **Position light indicator - 7**

This indicator illuminates when the light switch turns to position light.

### **Oil pressure indicator - 8**

The oil pressure indicator is on when the oil pressure is very low. Please have your vehicle stopped safely at once when the indicator is on, inspect and eliminate the fault.

### **Low fuel indicator- 9**

The fuel gauge indicator is on when the reserve fuel qty is less than 4L.

## FEATURES & CONTROLS

### **Turning light, RH(If equipped) - 10**

When switch turns to right turning light position, the indicator is on.

### **Drive mode - 11**

Display the current drive mode, there are 3 drive modes, 2WD, 4WD and 4WD-LOCK

### **EPS fault indicator - 12**

This indicator displays when a fault occurs in the Electronic Power Steering system. Please stop the vehicle and contact your dealer to eliminate the fault.

### **Parking brake indicator - 13**

This indicator displays when parking brake function is activated.

### **ADJ - mode adjust button - 14**

Use this button together with the “SEL” button to adjust functions on the dashboard. Refer to ‘Dashboard Navigation / Settings / Adjustments’.

### **Fuel gauge - 15**

Display the fuel level in the fuel tank.

## FEATURES & CONTROLS

### Rider Information Center - 16

Rider Information Center. This dashboard section can be toggled using the 'SEL' button to display: 'TOTAL' -The odometer accumulated vehicle distance traveled in miles/kilometers, 'TRIP' - The trip distance traveled, 'H' - The accumulated engine run time, 'V' - Battery voltage, 'Brightness' - Set the dashboard display brightness using the 'ADJ' button. "P" - fault code displays when the vehicle ECU detects a fault.

### Speedometer - 17

Display the current vehicle speed. (Speedometer section can be toggled to display the vehicle speed in Kilometers per hour (km/h) or Miles Per Hour (MPH) by the "ADJ" and "SEL" buttons.

### Bluetooth indicator - 18

This vehicle is equipped with bluetooth function. The bluetooth indicator will not light when it is not paired and connected to a phone. It will flash during pairing and connecting, and will remain on after pairing successfully and staying connected. The telephone indicator will not display when there is no call, it will flash when there is an incoming call, and it remains on when the call is connected. Short-press the SEL button to answer the call, and short-press ADJ button to finish the call.

Open the bluetooth function in your phone, then connect the vehicle's bluetooth feature using your phone.

#### **WARNING**

Do not operate the vehicle while using bluetooth. Always stop the vehicle before answering a call. Distracted driving can result in an accident causing serious injury or death.

## FEATURES & CONTROLS

### **Gear position indicator - 19**

Display the current gear position.

### **Coolant Temperature - 20**

This dashboard section displays the current coolant temperature, 'C' is low temperature, 'H' is high temperature. Both over-low and over-high are abnormal. Idle the vehicle to warm the engine when it's too cold, and park the vehicle when it's too hot to prevent the coolant from boiling. Keep the coolant temperature in a normal range.

### **SEL - mode select button - 21**

Use this button together with the "ADJ" button to adjust functions on the dashboard. Refer to 'Dashboard Navigation / Settings / Adjustments'.

### **Override indicator - 22**

When depress the override button, override indicator is on, 4WD-LOCK speed limitation will be released in this state.

### **Coolant temperature warning indicator - 23**

When the coolant temperature is higher than 115°C, the coolant temperature warning indicator will be on. When the coolant temperature is higher than 120°C, the temperature warning indicator will be on and also the warning buzzer will alarm.

## FEATURES & CONTROLS

### **Brake fault warning indicator - 24**

This indicator displays when brake fluid level is very low. Please add DOT4 brake fluid. Low brake fluid level may lead to air intake in the brake system, cause brake fault and lead to serious injury.

### **OPC indicator - 25**

When driver leaves the seat without parking, this indicator will be on and an alarm sounds.

## FEATURES & CONTROLS

### Dashboard Navigation / Settings / Adjustments

Item	Display	SEL	ADJ	Operation	Result
Odometer	TOTAL	Short press		Shift to trip	TRIP
Trip distance	TRIP	Short press		Shift to engine hour	Engine hour
			Long press	Trip resets to be zero	TRIP
Engine hour	H	Short press		Shift to fault code	P
Fault code	P	Short press		Shift to battery voltage	V
Voltage	V	Short press		Shift to be dashboard brightness	Display the class of brightness
Dashboard brightness	Level of brightness	Short press		Shift to Odometer	TOTAL
Home interface	Home interface		Short press	Adjust dashboard brightness	Home interface
Time setting and unit setting interface	Home interface	Long press		Shift to set time	Hour setting
	Hour setting	Short press		Shift to minute setting	Minute setting
			Short press	Add 1 by every press for hour	Hour setting
			Long press	Decrease the hour	Hour setting
	Minute setting	Short press		Shift to unit setting	Unit setting
			Short press	Add 1 by every press for minute	Minute setting
			Long press	Decrease the minute	Minute setting
	12/24 hour setting interface	Short press		Shift to unit setting	Speed unit setting interface
			Short press	Shift to time format	12/24 hour setting
	Unit setting interface	Short press		Back to home interface	Home interface
		Short press	Shift the unit for speed	Unit setting	

## OPERATION OF YOUR ATV

### Operation of Your Vehicle

#### Break-In Period

The break-in period for your new Vehicle is very important. Careful treatment of a new engine will result in more efficient performance and longer life for the engine. Perform the following procedures carefully.

1. Select an open area that allows room to familiarize yourself with vehicle operation and handling.
2. Place the Vehicle on a level surface.
3. Fill the fuel tank with gasoline.
4. Check the engine oil level. Add the recommended oil if necessary to maintain the oil level between the minimum and maximum indicators on the dipstick.
5. Position yourself in the operating position on the vehicle and start the engine. Allow the engine to idle for a short period before operating.
6. Press the foot brake, select the desired gear, and then release the foot brake.
7. Apply throttle. Drive slowly at first, varying throttle positions not more than  $\frac{1}{2}$  throttle for 10 hours or 100 miles, then another 10 hours or 100 miles of not more than  $\frac{3}{4}$  throttle (whichever interval arrives first). Do not operate at sustained idle or sustained wide open throttle.
8. Do not pull or carry any loads during the break-in period.
9. At the end of the break-in period, change the oil and filter (20hrs or 200 miles/320km).

## OPERATION OF YOUR ATV

### ⚠ CAUTION

During the break-in period:

- Do not load or tow cargo.
- Do not operate at sustained full throttle. Damage to engine parts or decrease engine life may result if excessive wide open throttle is used during the first 20 hours of use.
- Do not run engine with throttle over 1/2 open during the first 10 hours (or 100 miles/160km) of use.
- Do not run engine with throttle over 3/4 open during the first 10 to 20 hours (or the second 100 miles/160km) of use.
- Use of any oil other than those recommended may cause serious engine damage. CFMOTO recommends the use of 5W-40 for 1-cylinder 4-stroke engines. Changing engine oil viscosity to 10W-40 or 15W-40 due to hot environments is acceptable. Reference the chart below for ambient temperature and viscosity choice.

### Recommended Engine Oil Viscosity

Oil Viscosity				15W-40				
				10W-40				
				5W-40				
F°	-22	-4	14	32	50	68	86	104
C°	-30	-20	-10	0	10	20	30	40

## OPERATION OF YOUR ATV

### Pre-Ride Inspection

#### Perform the following procedures before operation:

1. Fill the fuel tank with gasoline.
2. Place the vehicle on a level ground to check the engine oil level. Add recommended engine oil if necessary to maintain the oil level between the minimum and maximum level marks of the dipsticks.
3. Drive slowly at first. Select an open area that allows room to familiarize yourself with vehicle operation and handling.
4. Vary throttle positions. Do not idle the vehicle sustainedly for long time.
5. Perform regular checks on fluid levels, controls and items outlined on the daily pre-ride inspection checklist.
6. Pull the load under the maximum weight requirement.
7. During the break-in period, change both the oil and oil filter at 20 hours or 320km .

#### **WARNING**

If a proper inspection is not done before each use, severe injury or death could result. Always inspect the vehicle before each use to ensure it is in proper operating condition.

## OPERATION OF YOUR ATV

### Starting the Engine

#### **WARNING**

Engine exhaust contains poisonous carbon monoxide and can cause loss of consciousness resulting in severe injury or death. Never run an engine in an enclosed area.

#### **CAUTION**

Operating the vehicle immediately after starting could cause engine damage. Allow the engine to warm up for several minutes before operating the vehicle.

### Starting a Cold Engine

1. Verify the gear selector is shifted to the Parking or Neutral position.
2. Apply the foot brake.
3. Turn the engine stop switch and main key switch to “” (ON)
4. Verify the throttle is completely closed, then push the start switch on the left-hand control.
5. Once the engine starts, continue to warm the engine for a short period before operating the vehicle.

## OPERATION OF YOUR ATV

### NOTE

- When the gear selector is in neutral position,if indicator light on dashboard does not come on,ask your dealer to inspect its electric circuit or adjust gear-shifting system.
- Engine can be started in any gear if rear brake pedal is applied. However it is recommended to shift into neutral or park before starting the engine.
- Completely close the throttle and start the engine by pushing the start switch.
- Do not activate the starting system more than 10 seconds on each attempt. If the engine fails to start, release the start switch, pause a few seconds before the next attempt, then push the start switch again. Each attempt should be as short as possible to preserve battery energy.
- If the battery is discharged, remove the battery to recharge.
- Continue warming up the engine until it idles smoothly before starting the Vehicle.

 <b>CAUTION</b>
--

See the“Break-In Period”section before operating the engine for the first time.
---

## OPERATION OF YOUR ATV

### Gear Selector Operation

#### Shifting

#### CAUTION

To avoid transmission damage, return the throttle to the closed position, stop the vehicle, and apply the foot brake before shifting.

#### NOTE

Low gear is the preferred transmission gear selection for all forward motion other than prolonged high speed travel.

#### Shifting out of Park

1. Verify the throttle is closed.
2. Apply the foot brake.
3. Shift to the desired gear by moving the gear selector along the shift guide.

#### Shifting: Neutral to High Gear

1. Verify the throttle is closed and the vehicle is stopped completely.
2. Apply the foot brake.
3. Shift to 'H' by moving the gear selector along the shift guide.

#### Shifting: High Gear to Low Gear

1. Verify the throttle is closed and the vehicle is stopped completely.
2. Apply the foot brake.
3. Shift to 'L' by moving the gear selector along the shift guide.

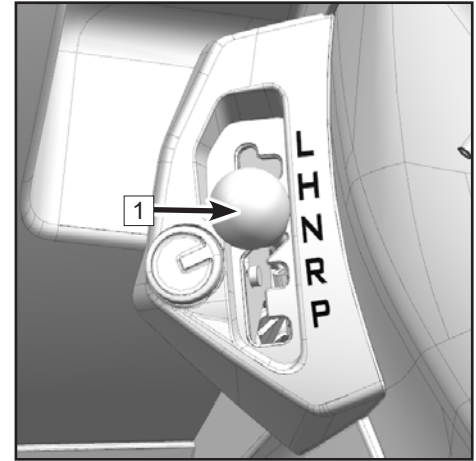

 Gear selector

## OPERATION OF YOUR ATV

### Shifting: Low Gear to High Gear

1. Verify the throttle is closed and the vehicle is stopped completely.
2. Apply the foot brake.
3. Shift to 'H' by moving the gear selector along the shift guide.

### Shifting: to Reverse Gear

1. Verify the throttle is closed and the vehicle is stopped completely.
2. Apply the foot brake.
3. Shift to 'R' by moving the gear selector along the shift guide.
4. Check behind you for people or obstacles, then release the rear brake pedal.
5. Apply the throttle lever gradually and continue to watch behind you while moving backward.

 <b>WARNING</b>
--

When you shift into reverse, make sure there are no obstacles or people, and the area is safe behind you. When it is safe to proceed, go slowly.
--

### Shifting: Reverse to Park

1. Verify the throttle is closed and the vehicle is stopped completely.
2. Apply the foot brake.
3. Shift to 'P' by moving the gear selector along the shift guide.

## OPERATION OF YOUR ATV

### NOTE

The gear selector must not be shifted into reverse gear without applying the foot brake.

The gear shift indicators should display corresponding to the actual gear position, if the indicator does not display, ask your dealer to inspect the vehicle electrical circuit or adjust the gear shifting system.

Due to the synchronizing mechanism in the engine, an indicator may not display until Vehicle starts moving.

Do not use high gear for continuous slow speed travel or towing, as this can lead to excessive heating of the clutch system, which may damage components.

## OPERATION OF YOUR ATV

### Hauling and Towing Cargo

Your vehicle is equipped with front and rear cargo racks, and a hitch receptacle for towing. Follow these guidelines for hauling and towing of cargo:

#### **WARNING**

Overloading the vehicle or carrying or towing cargo improperly can alter vehicle handling and may cause loss of control or brake instability. Always follow these precautions when hauling cargo:

- Never exceed the stated load capacity for this vehicle.
- Reduce speed when hauling or towing loads.
- When operating over rough or hilly terrain, reduce speed and cargo to maintain stable driving conditions.
- Weight distribution on the front and rear racks should be as far forward and as low as possible. Carrying a high load raises the center of gravity and creates an unstable operating condition. Reduce load weight when the cargo center of gravity is high. When handling off-centered loads that cannot be centered, secure the load and operate with extra caution.
- All loads must be secured before operation. Unsecured loads may shift and create unstable operating conditions, which could result in loss of control of the vehicle.

## **OPERATION OF YOUR ATV**

- When operating with loads extending beyond the rack. Stability and maneuverability may be adversely affected, causing the machine to overturn.
- Carrying a load on only the front rack or the rear rack may cause an imbalanced condition and increases the possibility of vehicle overturn. Balance loads proportionally between the front rack and the rear rack, but do not exceed the stated load capacity.
- Use extreme caution when applying brakes with a loaded vehicle. Avoid terrain or situations that may require backing downhill.
- Always attach to the towable using the hitch point. Never exceed the recommended tongue weight.
- While towing, the vehicle should never exceed 10 mph (16 km/h) while towing a load on a level surface. Vehicle speed should never exceed 5mph (8 km/h) when towing loads in rough terrain, while cornering, or while ascending or descending a hill.
- Do not obstruct the headlight when loading the front rack.
- Always use low gear while towing to avoid clutch wear and belt issues.
- Using chains, straps, rope or other materials to tow objects is not recommended, as these items could get caught in the rear wheels, resulting in vehicle damage or personal injury.

## OPERATION OF YOUR ATV

### Load Distribution

Your vehicle has been designed to carry or tow a certain amount of load. Always read and understand the load distribution warnings listed on the warning labels, and never exceed the specified weights. Cargo weight should be mounted as low as possible. When operating over rough or hilly terrain, reduce speed and cargo to maintain stable driving conditions.

If a trailer is used behind the vehicle make sure that its hitch is compatible with the one on the vehicle. Make sure the trailer is horizontal with the vehicle. (In some instances a special extension may have to be installed on the vehicle hitch). Use security chains or cables to secure the trailer with the vehicle.

This vehicle may require additional stopping distance if hauling heavy loads, especially on inclined surfaces and when a passenger is on board. Improperly loading a trailer may cause loss of control. Respect the recommended maximum hauling capacity and maximum tongue load. Make sure there is at least some weight on the tongue.

Always make sure load is evenly distributed and safely secured on the trailer; an evenly balanced trailer is easier to control. Always put the shift lever to L (low range) for hauling a trailer in addition to providing more torque, operating in low range helps account for the increased load on the rear tires.

When stopped or parked, block the vehicle and trailer wheels from possible movement. Use caution when disconnecting a loaded trailer; it or its load may topple on you or others. When hauling a trailer, respect the following maximum hauling capacity.

## OPERATION OF YOUR ATV

### MAXIMUM HAULING CAPACITY

TRAILER LOAD ALLOWED		TONGUE WEIGHT ALLOWED	NOTE	
CF600ATR-2S	300 kg	25 kg	Trailer without brakes	Includes trailer and trailer load. Ensure to properly load the trailer so that tongue is always pushing on hitch support and not pulling on hitch ball.
CF600ATR-2L	300 kg			

NOTE: Includes trailer and trailer load. Ensure to properly load the trailer so that tongue is always pushing on hitch support and not pulling on hitch ball.

#### **WARNING**

Stay clear from the area between vehicle and trailed vehicle.

#### **WARNING**

Strictly follow the instructions outlined in the operator's manual of the mounted or trailed machinery or trailer, and not to operate the combination vehicle - machine or vehicle - trailer unless all instructions have been followed.

## OPERATION OF YOUR ATV

**Place a support under vehicle.**

**NOTE:** Before jacking ensure that all wheels are locked.

**NOTE:** When the brake lock is applied ensure that the vehicle stays securely in place.

<b> WARNING</b>
--

DO NOT OVERLOAD your jack beyond its rated capacity. Use jack which is designed for use on hard level surfaces only. Use lifting device only. DO not move or dolly the vehicle while on the jack. Refer to jack warnings and operating instructions prior to use.
---

<b>NOTE:</b>
--------------

Ensure that 4 WH is engaged and brake is locked.
--

## OPERATION OF YOUR ATV

### **Intended Use**

The vehicle is designed solely for use in agricultural or similar operations. Use in any other way is considered as contrary to the intended use. Compliance with and strict adherence to the conditions of operation, service, and repair as specified by the manufacturer, also constitute essential elements of the intended use. The vehicle should be operated, serviced, and repaired only by persons who are familiar with its particular characteristics and who are acquainted with the relevant safety procedures. Accident prevention regulations, all other generally recognized regulations on safety and occupational medicine, and all road traffic regulation must be observed at all times. Any arbitrary modifications carried out to this vehicle may relieve the manufacturer of liability for any resulting damage or injury. The agricultural vehicles can not be used in conditions which may cause the risk of contact with hazardous substances, e.g. spraying of pesticides. In addition, the agricultural vehicles also can not used in conditions which may risk of falling and penetrating objects.

## OPERATION OF YOUR ATV

### Hauling a Load

Never pull a load by attaching it to the cage. It can cause the vehicle to tip stalled to pull a load.

In an emergency situation, use the recovery hook to recover a stuck vehicle.

When pulling loads with a chain or cable, ensure that there is no slack before starting and maintain tension while pulling.

When pulling loads with a chain or cable, be sure to brake progressively. The inertia of the load could lead to an impact.

When hauling a load, respect the maximum hauling capacity. See PULLING A TRAILER subsection.

 <b>WARNING</b>
--

Slack can cause the chain or cable to break and snap back.
--

When pulling another vehicle, be sure that someone is controlling the pulled vehicle. They must brake and steer to prevent the vehicle from going out of control.

Reduce your speed when hauling a load and turn gradually. Avoid hills and rough terrain. Never attempt steep hills. Allow more distance for braking, especially on inclined surfaces and when a passenger is on board.

Be careful not to skid or slide.

### Accessories and Modifications

If no such attachment points are foreseen, the operator's manual shall prohibit the installation of a front end loader.

This T3 has not attachment points for front end loader. Do not install front loader.

**FOR MORE INFORMATION ABOUT Vehicle SAFETY, PLEASE CONTACT WITH YOUR DEALER.**

## OPERATION OF YOUR ATV

Where a designated attachment point is provided on the towbar:

**Either**

a) Pass the cable through the attachment point and clip it back on itself ( FIG.1 )

**Or:**

b) Attach the clip directly to the designated point ( FIG.2 ). This alternative must be specifically permitted by the trailer manufacturer since the clip may not be sufficiently strong for use in this way.

( FIG.1 )

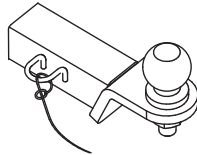

( FIG.2 )

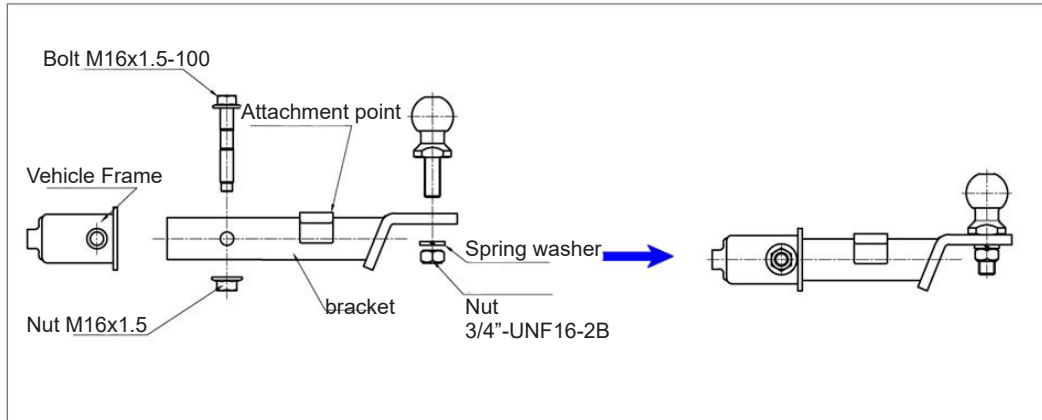
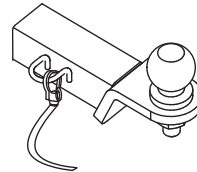

## OPERATION OF YOUR ATV

### **Driving Safely**

#### **Responsibilities of the operator**

As the operator of this vehicle, your common sense, judgment, and abilities are the only factors that will prevent injury to yourself, to others around you, and/or damage to the vehicle or environment.

#### **Recreational, group, and distance riding**

Always keep a safe distance from other riders ahead of you and behind you when riding in a group. Never operate carelessly or make unexpected maneuvers with other vehicles close by. Stay on designated trails and riding areas, and discourage others from operating in unauthorized locations.

## OPERATION OF YOUR ATV

### **Practice!**

The driving procedures described in this manual should be practiced at slow speed many times in a large area with no obstacles. If an incorrect technique is used, your vehicle may continue to go straight. If the vehicle does not turn, stop and practice the procedure again. If the riding surface is slippery or loose, it may help to transfer more of your weight to the front wheels by moving forward on the seat. Once you have learned the proper techniques, you should be able to perform maneuvers at higher speeds or in tighter curves.

Improper driving procedures such as abrupt throttle changes, excessive braking, incorrect body movements, or too much speed for the sharpness of the turn may cause the Vehicle to tip. If the Vehicle begins to tip over to the outside while negotiating a turn, lean more to the inside. It may also be necessary to gradually let off on the throttle and steer to the outside of the turn to avoid tipping over.

Remember: Avoid higher speeds until you are thoroughly familiar with the operation of your Vehicle.

### **NOTE**

Low gear is the preferred transmission gear selection for all forward motion other than prolonged high speed travel. Do not use high gear for continuous slow speed travel or towing, as this can lead to excessive heating of the clutch system, which may damage components.

## OPERATION OF YOUR ATV

### Driving Procedures

1. Sit upright with both feet on the footrests and both hands on the handlebars.
2. Start the engine and allow it to warm up, apply the brakes, then shift the transmission into gear.
3. Check your surroundings and determine your path of travel.
4. Release the brakes.
5. Slowly depress the throttle with your right thumb and begin driving. Vehicle speed is controlled by the amount of throttle opening.
6. Drive slowly. Practice maneuvering and using the throttle and brakes on level surfaces.

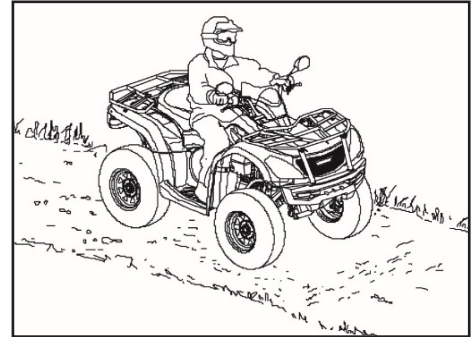

## OPERATION OF YOUR ATV

### Making Turns

To make a turn, steer in the direction of the turn, leaning your upper body to the inside of the turn while supporting your weight on the outer footrest. This technique alters the balance of traction between the wheels, allowing turn to be made smoothly. The same leaning technique should be used for turning in reverse.

### NOTE

Practice making turns at slow speeds before attempting to turn at faster speeds.

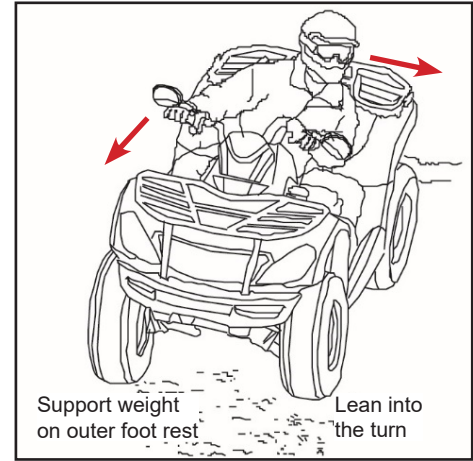

### **WARNING**

Turning at sharp angles or at excessive speeds can result in vehicle overturn and lead to serious injury. Avoid turning at sharp angles. Never make turns at high speeds.

## OPERATION OF YOUR ATV

### ATV turning dynamics

To achieve maximum traction while operating in 2WD or 4WD, the two rear wheels perform as one axle and turn together at the same speed. Furthermore, when operating in 4WD-LOCK mode, the front wheels will also turn together at the same speed. Therefore, unless the wheel on the inside of the turn is allowed to slip or lose some traction, the ATV will resist turning. The special turning technique described in this manual must be used to allow the ATV to make turns quickly and easily. It is essential that this skill be learned first at low speed.

#### **WARNING**

Always follow proper procedures for turning as described in this Owner's Manual. Practice turning at low speeds before attempting to turn at faster speeds. Do not turn at speeds too fast for your skills or the conditions. Operate at a slow speed and allow extra time and distance for maneuvers when in 4WD - LOCK ( DIFF. LOCK ).

As you approach a curve, slow down and begin to turn the handlebars in the desired direction. As you do so, put your weight on the footboard to the outside of the turn (opposite your desired direction) and lean your upper body into the turn. Use the throttle to maintain an even speed through the turn. This maneuver will let the wheel on the inside of the turn slip slightly, allowing the Vehicle to make the turn properly.

### Turning on curves

As you approach a curve, slow down and begin to turn the handlebars in the desired direction. As you do so, put your weight on the foot board to the outside of the turn (opposite the desired direction) and lean your upper body into the turn. Use the throttle to maintain an even speed through the turn. This maneuver will let the wheel on the inside of the turn slip slightly, allowing the ATV to maneuver the turn properly.

## OPERATION OF YOUR ATV

### Driving in reverse

#### To operate in reverse:

1. Ensure the throttle is closed and the vehicle is stopped completely.
2. Apply the foot brake, then shift the transmission into reverse gear.
3. Check for obstacles or people behind the vehicle.
4. When it's safe to proceed, release the brakes, slowly press the throttle with your right thumb, and back slowly. Vehicle speed is controlled by the amount of throttle opening.

### NOTE

Your ATV is equipped with a reverse speed limiter. The override button cannot be used. Do not operate at wide open throttle. Open the throttle just enough to maintain a desired speed.

Follow these precautions when operating in reverse:

- Always avoid backing downhill.
- Back slowly.
- When in reverse, apply the brakes lightly for stopping.
- Avoid turning at sharp angles in reverse.
- Never open the throttle suddenly while backing.

 <b>WARNING</b>
--

Failure to use caution when operating in reverse can result in serious injury or death.
---

## OPERATION OF YOUR ATV

### Driving on slippery surfaces

Whenever driving on slippery surfaces such as wet trails, loose gravel, sand, or during freezing weather, follow these precautions:

- Slow down when entering slippery areas.
- Maintain a high level of alertness, reading the trail in front of you as you drive. Avoid quick, sharp turns which can cause skids.
- Correct a skid by turning the handlebars in the direction of the skid and shifting your body weight forward.
- Driving with 4WD engaged can assist in controlling the vehicle in slippery areas.

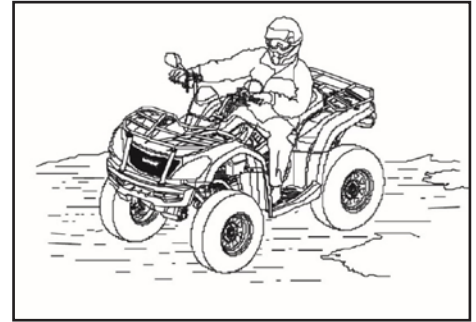

### **⚠ CAUTION**

Severe damage to drive train may occur if 4WD is engaged while the wheels are spinning. Always engage 4WD when the wheels are at rest.

### **⚠ WARNING**

Failure to exercise care when operating on slippery surfaces can result in loss of tire traction and loss of control, an accident, and serious injury or death. Never apply the brakes during a skid. Do not operate on excessively slippery surfaces. Always reduce speed and use additional caution.

## OPERATION OF YOUR ATV

### Driving on rough terrain

Whenever driving on rough surfaces such as trails with large rocks or other obstacles, follow these precautions:

- Slow down when encountering rough terrain.
- Maintain a high level of alertness, reading the trail in front of you as you drive. Avoid quick, sharp turns which can cause a loss of control.
- Shift your body weight to counteract the weight of the vehicle if it tips to one side.
- Driving with 4WD or 4WD-LOCK engaged can assist in controlling the vehicle.



### Driving over obstacles

Be alert! Learn to look ahead and to read the terrain as you drive. Be constantly alert for hazards such as logs, rocks, and low hanging branches.

Never attempt to cross over an obstacle higher than the ground clearance of the vehicle.



### **WARNING**

Severe injury or death can result if your vehicle comes in contact with obstacles. Travel with caution on unfamiliar terrain.

## OPERATION OF YOUR ATV

### Driving through water

Your ATV can operate through water with a maximum recommended depth equal to the bottom of the footrests. Follow these procedures when operating through water:

- Determine water depths and current before crossing.
- Choose a crossing where both banks have gradual inclines.
- Proceed slowly, avoiding rocks and obstacles if possible.
- After crossing, dry the brakes by applying light pressure to the lever until braking action is normal.



### **⚠️ WARNING**

Avoid operating the vehicle through deep or fast-flowing water. If you cannot avoid water that exceeds the recommended maximum depth, go slowly, balance your weight carefully, avoid sudden movements, and maintain a slow and steady forward motion. Do not make sudden turns or stops, and do not make sudden throttle changes.

## OPERATION OF YOUR ATV

### Drying the CVT system after submersion

If water has been ingested into the CVT housing, the drive belt will likely slip and poor performance will result. To expel water and dry the CVT housing; Drain the CVT housing, place the vehicle in neutral, and raise the engine rpm for several minutes to dry the CVT components. Release the throttle and shift into low gear, then test the performance of the vehicle. Repeat as necessary until you are satisfied all the water has been expelled. Contact your dealer if vehicle performance issues continue.

### NOTE

After running the vehicle in water, it is critical to have the vehicle serviced as outlined in the maintenance schedule. The following areas need special attention: engine oil, front and rear gear cases and all grease locations. If your vehicle becomes immersed, and it's impossible to take it to your dealer before starting it, follow the steps described in this manual to remove water from the air box and engine.

### CAUTION

Major engine damage can result if the vehicle is not thoroughly inspected after operation in water. If water has been ingested into the CVT housing, follow the procedure in this manual for drying out the CVT clutch system. Have the vehicle serviced by your dealer promptly if your vehicle becomes immersed or stalls in water that exceeds the footrest level. It is important to contact your dealer for service before starting the engine, as water may have been ingested in the air box and engine.

## OPERATION OF YOUR ATV

### Driving Uphill

Whenever traveling uphill, follow these precautions:

- Always travel straight uphill.
- Avoid steep hills (20° Maximum).
- Keep both feet on the footrests.
- Shift your weight forward.
- Maintain a steady rate of speed and throttle opening.
- Remain alert and be prepared to take emergency action. This may include quick dismounting of the vehicle.

### If all forward speed is lost:

Keep your weight uphill and release the throttle.

Apply the front brake. When fully stopped, apply rear brake as well, then shift gear selector into park position.

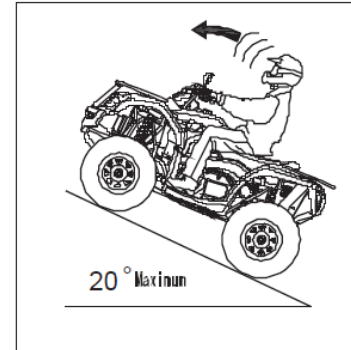

## OPERATION OF YOUR ATV

### **If the Vehicle begins rolling backwards:**

Keep your weight uphill. Never apply engine power. Never apply the foot brake while rolling backwards.

Apply the front brake. When fully stopped, apply the rear brake and shift the gear selector into park position.

Dismount on uphill side, or to either side if Vehicle is pointed straight uphill. Turn the Vehicle around and remount following the procedure described in the manual.

### **WARNING**

Braking and handling are greatly affected when operating in hilly terrain. Improper procedure could cause loss of control or overturn and result in serious injury or death.

Avoid climbing steep hills (20° Maximum).

Use extreme caution when operating on hills, and follow proper operating procedures outlined in the owner's manual.

## OPERATION OF YOUR ATV

### Sidehilling

#### **⚠️ WARNING**

Improperly crossing hills or turning on hills can result in loss of control or vehicle overturn, resulting in severe injury or death. Avoid crossing the side of a hill when possible. Follow proper procedures as outlined in the owner's manual.

Sidehilling can be a dangerous type of driving and should be avoided if at all possible. If you do enter into a situation where sidehilling is necessary, follow these precautions:

- Slow down.
- Lean into the hill, transferring your upper body weight toward the hill while keeping your feet on the footrests.
- Steer slightly into the hill to maintain vehicle directions.

#### **⚠️ CAUTION**

If the vehicle begins to tip, quickly turn the front wheel downhill, if possible, or dismount on the uphill side immediately!

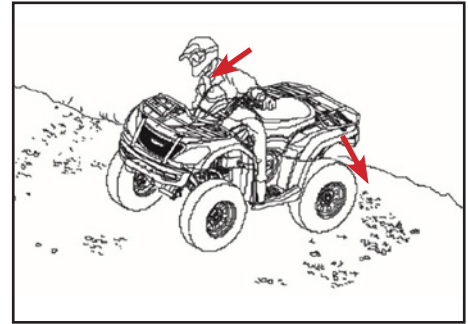

## OPERATION OF YOUR ATV

### Driving downhill

When traveling down a hill, follow these precautions:

- Never operate on hills over 22 degrees incline or hills too steep for your abilities.
- Slow down.
- Shift your weight to the rear of the vehicle.
- Always travel directly downhill.
- Utilize the engine braking function and apply the foot brake lightly to aid in slowing. Familiarize yourself with operation of these braking functions during downhill descents.
- Driving with 4WD or 4WD-LOCK engaged can assist in controlling the vehicle.

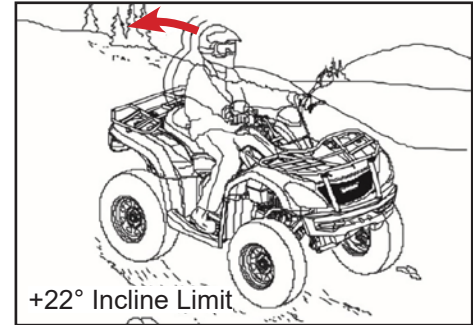

### **⚠️ WARNING**

Excessive downhill speed can cause loss of control and lead to serious injury or death. Always reduce speed when traveling downhill.

## OPERATION OF YOUR ATV

### Turning Around on a Hill

One maneuver that can be used when it's necessary to turn around if stranded while climbing a hill is the K-turn:

1. Release the throttle, then apply the hand and foot brake while keeping your body weight uphill.
2. Shift the gear selector lever to the low gear position. Shut off the engine.
3. Keeping the hand brake applied, dismount on the right side of the vehicle if the vehicle is pointed straight uphill.

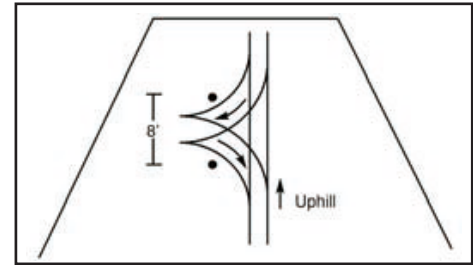

**NOTE: Always dismount on the uphill side when the vehicle is pointed in a direction other than uphill.**

4. Keeping the hand brake applied, move uphill (in front) of the vehicle, and pull on the right handle bar to turn the steering full left (front brake will now be closest to you).
5. Slowly release the hand brake lever, and use it to control the descent of the vehicle, which will roll downhill and to your right (as viewed from the vehicle front) until it's pointing across the hill or slightly downward. The vehicle's rolling weight is neutralized, and vehicle remount is now possible.
6. Remount the vehicle from the uphill side and shift the gear selector lever to the parking position, keeping your body weight uphill. Keep the hand brake or foot brake applied at all times if possible.
7. Restart the engine. Press the foot brake, and shift the gear selector lever to low gear position.
8. Release the brakes and proceed slowly downhill, controlling speed with the brakes, until the vehicle is on more level ground.

## OPERATION OF YOUR ATV

### Parking on an incline

Avoid parking on an incline if possible. If it's unavoidable, follow these precautions:

- Turn the engine off.
- Place the gear selector to parking position.
- Always block the rear wheels on the downhill side. Refer to the illustration.

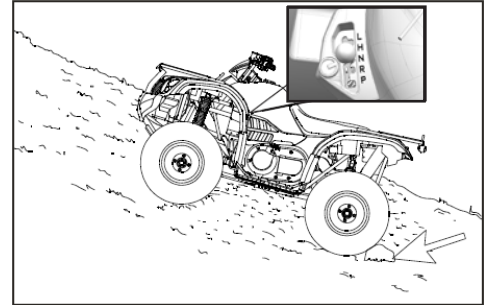

### **⚠ CAUTION**

The rear output shaft is locked when the transmission is in the parking position.

## MAINTENANCE & LUBRICATION

### Maintenance

Following the maintenance schedule in your owner's manual will help keep your vehicle in the safest, most reliable condition. Inspection, adjustment, and lubrication of important components are explained in the maintenance schedules.

Inspect, clean, lubricate, adjust, and replace parts as necessary. When inspection reveals the need for replacement parts, please use genuine parts available from your dealer.

### Severe Use Definition

CFMOTO defines severe vehicle use as:

- Frequent immersion in mud, water or sand
- Racing or race-style high RPM use
- Prolonged low speed, heavy load operation
- Extended engine idle
- Short trip, cold weather operation
- Vehicles used in commercial operations

**For vehicles that are subjected to severe use, reduce all maintenance and service intervals by 50%.**

### NOTE

Periodic service and adjustments are critical. If you are not familiar with performing safe service and adjustment procedures, have a qualified dealer perform the required maintenance for you.

## MAINTENANCE & LUBRICATION

### NOTE

Pay special attention to the engine oil level during cold weather operation. A rise in engine oil level can indicate contaminants collecting in the oil sump or crankcase. Change oil immediately if the oil level begins to rise. Monitor the oil level, and if it continues to rise, discontinue use and determine the cause, or see your dealer.

### Periodic Maintenance Schedule and Icon Key

Maintenance intervals in the following schedules are based upon average riding conditions and an average operating speed of approximately 12.4 mph (20 km/h). Vehicles subjected to severe or commercial use must be inspected and serviced more frequently.

The following icon keys are used to note special circumstances:

- ▶ = Severe Use Item. Reduce interval by 50% on vehicles subjected to severe use.
- = Have an authorized dealer perform repairs that involve this component or system.
- = Emissions related components. Have an authorized dealer perform repairs that involve this component or system.

### **WARNING**

Procedures marked as '■' means if repair is required, have an authorized dealer perform repairs that involve this component or system. Improperly performing the procedure could result in component failure and lead to serious injury or death.

## MAINTENANCE & LUBRICATION

### KEY POINTS OF LUBRICATION SCHEDULE:

Check all components at the intervals outlined in the Periodic Maintenance Schedule. Items not listed in the schedule should be lubricated at the general lubrication interval.

- Change lubricants more often under severe use, such as wet or dusty conditions.
- Use All Season Grease on pivot points.
- Lubricate every 500 miles (800 km), before long periods of storage, after pressure washing, or after submerging drive system.

Item	Lubricant	Method
Engine oil	SAE 10W-40 SAE 5W-40 / SAE 15W-40	Screw off, clean, insert and pull out dipstick to check oil level
Brake fluid	DOT4	Keep level between upper and lower lines
Front gear case oil	SAE80W-90 GL-5	Oil capacity: 200 mL )
Rear gear case oil	SAE80W-90 GL-5	Oil capacity: 230 mL )
Suspension pivots and drive train	All Season Grease	Grease gun - Pump grease until it begins to flow from the pivot point

## MAINTENANCE & LUBRICATION

### Pre-Ride Maintenance Checklist

Perform these inspections before operating the vehicle:

Item		Maintenance before operation			
		Hour	Calendar	Miles (km)	Remarks
■	Steering system	-	Pre-Ride	-	Visually inspect, test, or check components. Make adjustments and/or schedule repairs when required.
■	Throttle return	-	Pre-Ride	-	
	Front suspension and axles	-	Pre-Ride	-	
	Rear suspension and axles	-	Pre-Ride	-	
	Tires	-	Pre-Ride	-	
	Brake fluid level	-	Pre-Ride	-	
	Brake lever / foot brake function	-	Pre-Ride	-	
	Brake system function	-	Pre-Ride	-	
	Wheels / fasteners	-	Pre-Ride	-	
	Engine oil level	-	Pre-Ride	-	
▶	Air filter / Air box and connections	-	Pre-Ride	-	Visually inspect. Replace filter when dirty.

▶ = Severe Use Item. Inspect frequently on vehicles subjected to severe use.

■ = Have an authorized dealer perform repairs that involve this component or system.

● = Emissions related components. Have an authorized dealer perform repairs that involve this component or system.

## MAINTENANCE & LUBRICATION

Item		Maintenance before operation			
		Hour	Calendar	Miles (km)	Remarks
▶	Air box sediment tube	-	Pre-Ride	-	Inspect. If deposits are visible, clean intake tubes, air box, and replace air filter.
▶	CVT sediment tube	-	Pre-Ride	-	Inspect. If deposits are visible, drain / clean the CVT or have it serviced by a dealer.
■	Headlight aim / General lighting and turn indicators (if equipped)	-	Pre-Ride	-	Inspect. Adjust or replace lights when necessary.
▶	Radiator	-	Pre-Ride	-	Inspect for mud or debris blocking airflow. Clean surfaces when necessary.

▶ = Severe Use Item. Inspect frequently on vehicles subjected to severe use

■ = Have an authorized dealer perform repairs that involve this component or system.

● = Emissions related components. Have an authorized dealer perform repairs that involve this component or system.

## MAINTENANCE & LUBRICATION

### Break-In Maintenance Checklist

Perform these maintenance items when the vehicle break-in is completed:

Item		Break-in Maintenance (Perform at the interval that arrives first)			
		Hour	Calendar	Miles (km)	Remarks
	General lubrication	20	-	200 (320)	Lubricate all grease points, pivots, cables, etc.
	Engine oil / oil filter / oil strainer	20	-	200 (320)	Change oil and filter. Clean oil strainer.
▶	Engine air filter	20	-	200 (320)	Inspect; replace if dirty; do not clean
■	Engine valve clearance	20	-	200 (320)	Check and adjust as necessary.
	Front / Rear gear case oil	20	-	200 (320)	Check level. Inspect for leaks.
	Coolant	20	-	200 (320)	Check level. Inspect for leaks.
▶	Brake pads	20	-	200 (320)	Inspect pad thickness.

▶ = Severe Use Item. Reduce interval by 50% on vehicles subjected to severe use.

■ = Have an authorized dealer perform repairs that involve this component or system.

● = Emissions related components. Have an authorized dealer perform repairs that involve this component or system.

## MAINTENANCE & LUBRICATION

Item		Break-in Maintenance (Perform at the interval that arrives first)			
		Hour	Calendar	Miles (km)	Remarks
	Battery	20	-	200 (320)	Check terminals, clean, test battery condition if required.
■	Idle condition	20	-	200 (320)	Inspect for proper rpm. See dealer for service if out of spec or erratic.
■	Steering / Wheel Alignment	20	-	200 (320)	Inspect steering system. See dealer for service if wheel alignment is required.
▶	Foot brake / Hand brake	20	-	200 (320)	Inspect function. Adjust as necessary.
	Gear cases, CV shafts, Propshafts	20	-	200 (320)	Inspect for leaks.
	Engine hoses, gaskets and seals	20	-	200 (320)	Inspect for leaks.

▶ = Severe Use Item. Reduce interval by 50% on vehicles subjected to severe use.

■ = Have an authorized dealer perform repairs that involve this component or system.

● = Emissions related components. Have an authorized dealer perform repairs that involve this component or system.

## MAINTENANCE & LUBRICATION

### Periodic Maintenance Schedule

Perform these maintenance items when the vehicle break-in is completed:

Item		Periodic Maintenance Intervals (Perform at the interval that arrives first)			
		Hour	Calendar	Miles (km)	Remarks
▶	Brake pads	10	Monthly	100 (160)	Inspect pad thickness.
	Battery	20	--	200 (320)	Check terminals. Clean and test battery condition as necessary.
	Engine hoses, gaskets and seals	20	-	200 (320)	Inspect for leaks.
▶	Air filter	50h	--	500 (800)	Always inspect pre-ride. Inspect frequently if subjected to severe use. Replace if dirty. Do not clean.
▶	General lubrication	50h	3M	500 (800)	Lubricate all fittings, pivots, cables, etc.

▶ = Severe Use Item. Reduce interval by 50% on vehicles subjected to severe use.

■ = Have an authorized dealer perform repairs that involve this component or system.

● = Emissions related components. Have an authorized dealer perform repairs that involve this component or system.

## MAINTENANCE & LUBRICATION

Item		Periodic Maintenance Intervals (Perform at the interval that arrives first)			
		Hour	Calendar	Miles (km)	Remarks
▶	Front gear case oil	50h	12M	500 (800)	Inspect level. Change yearly if hours or distance interval is not met.
▶	Rear gear case oil	50h	12M	500 (800)	Inspect level. Change yearly if hours or distance interval is not met.
▶	Engine oil / oil filter / oil strainer	100h	12M	1000 (1600)	Inspect for color change. Change if dirty and clean strainer. Change yearly if hours or distance interval is not met.
	Cooling system	50h	6M	500 (800)	Test coolant strength. Pressure test system yearly.

▶ = Severe Use Item. Reduce interval by 50% on vehicles subjected to severe use.

■ = Have an authorized dealer perform repairs that involve this component or system.

● = Emissions related components. Have an authorized dealer perform repairs that involve this component or system.

## MAINTENANCE & LUBRICATION

Item		Periodic Maintenance Intervals (Perform at the interval that arrives first)			
		Hour	Calendar	Miles (km)	Remarks
▶	Radiator	50h	6M	500 (800)	Inspect; clean external surfaces. Clean more frequently if subjected to severe use.
■	Steering system	50h	6M	500 (800)	Inspect. Lubricate.
▶	Front suspension	50h	6M	500 (800)	Lubricate. Check fasteners.
▶	Rear suspension	50h	6M	500 (800)	Lubricate. Check fasteners.
▶	Gear shift	50h	1M	500 (800)	Inspect, lubricate, adjust as necessary.
▶ ■	Throttle body / throttle cable	50h	6M	500 (800)	Inspect. Clean carbon deposits. Inspect cable and lubricate frequently if subjected to severe use.

▶ = Severe Use Item. Reduce interval by 50% on vehicles subjected to severe use.

■ = Have an authorized dealer perform repairs that involve this component or system.

● = Emissions related components. Have an authorized dealer perform repairs that involve this component or system.

## MAINTENANCE & LUBRICATION

Item		Periodic Maintenance Intervals (Perform at the interval that arrives first)			
		Hour	Calendar	Miles (km)	Remarks
▶ ■	CVT drive belt	50h	12M	1500 (2400)	Inspect. Replace as necessary. See dealer for service.
■	CVT drive and driven pulleys	100h	12M	500 (800)	Clean and Inspect pulleys. Replace worn parts. See dealer for service.
	Fuel filter and hoses	100h	24M	2000 (3200)	Inspect routing and condition. Replace filter and high-pressure hoses every 4 years.
	Cooling hoses	100h	--	1000 (1600)	Inspect routing and condition.
▶	Valve clearance	100h	--	2000 (3200)	Inspect and adjust as necessary. See dealer for service.

▶ = Severe Use Item. Reduce interval by 50% on vehicles subjected to severe use.

■ = Have an authorized dealer perform repairs that involve this component or system.

● = Emissions related components. Have an authorized dealer perform repairs that involve this component or system.

## MAINTENANCE & LUBRICATION

Item		Periodic Maintenance Intervals (Perform at the interval that arrives first)			
		Hour	Calendar	Miles (km)	Remarks
•	Fuel system	100h	12M	500 (800)	Inspect fuel tank, cap, fuel pump and fuel pump relay.
	Spark plug	100h	24M	2000 (3200)	Inspect; Replace if worn or fouled.
■	Engine mounts	100h	12M	1500 (2400)	Inspect condition.
	Exhaust pipe and spark arrestor	100h	12M	500 (800)	Inspect. Clean spark arrestor.
▶	Wiring, fuses, connectors, relays, and cables	100h	12M	1000 (1600)	Inspect wire routing for wear, security. Apply dielectric grease as necessary to connectors subjected to water, mud, etc.

▶ = Severe Use Item. Reduce interval by 50% on vehicles subjected to severe use.

■ = Have an authorized dealer perform repairs that involve this component or system.

• = Emissions related components. Have an authorized dealer perform repairs that involve this component or system.

## MAINTENANCE & LUBRICATION

Item		Periodic Maintenance Intervals (Perform at the interval that arrives first)			
		Hour	Calendar	Miles (km)	Remarks
▶ ■	Wheel bearings	100h	12M	1500 (2400)	Inspect for noise or looseness Replace as necessary.
▶	Safety Belts	100h	12M	2000 (3200)	Visually inspect belts and test latches. Clean latch mechanism more often if used in severe conditions.
	Coolant	200h	24M	4000 (6400)	Change coolant every 2 years if hours or distance interval is not met.
▶	Brake fluid	200h	24M	1000 (1600)	Inspect fluid for color change. Change fluid every two years.

▶ = Severe Use Item. Reduce interval by 50% on vehicles subjected to severe use.

■ = Have an authorized dealer perform repairs that involve this component or system.

● = Emissions related components. Have an authorized dealer perform repairs that involve this component or system.

## MAINTENANCE & LUBRICATION

Item		Periodic Maintenance Intervals (Perform at the interval that arrives first)			
		Hour	Calendar	Miles (km)	Remarks
	Idle condition	--	12M	--	Inspect for proper rpm. See dealer for service if out of spec or erratic.
■	Steering / Wheel Alignment	--	12M	--	Inspect steering system. See dealer for service whenever steering parts or wheel alignment are required.
▶	Foot brake height	--	12M	--	Inspect. Replace brake pads or adjust height as required.

▶ = Severe Use Item. Reduce interval by 50% on vehicles subjected to severe use.

■ = Have an authorized dealer perform repairs that involve this component or system.

● = Emissions related components. Have an authorized dealer perform repairs that involve this component or system.

## MAINTENANCE & LUBRICATION

### Maintenance Procedures

#### Engine oil check

Always check and change the engine oil at the intervals outlined in the Maintenance Schedule.

1. Place the ATV on a level surface.
2. Start the engine and let it idle for (20~30) seconds. Stop the engine.
3. Wait a short period for the oil to settle.
4. Remove access cover **1** by grasping the lower right portion and pulling firmly.
5. Unscrew the oil dipstick **2** out and wipe off with a clean cloth.
6. Insert the dipstick into the oil filler hole. Do not reinstall it.
7. Remove the dipstick again and check the oil level indication. Maintain the oil level between the upper and lower indicators.
8. Reinstall the dipstick into the oil filler hole, hand-tighten it, and reinstall the access cover.

#### NOTE

Access cover grommets may come loose. Ensure they are in place before reinstalling the cover.

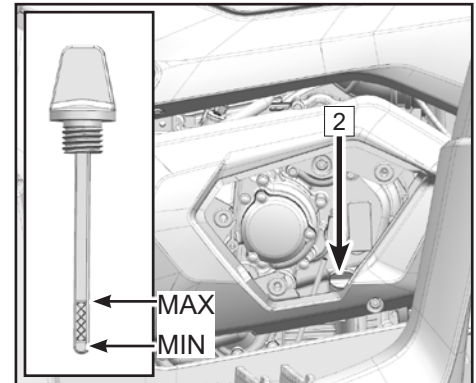
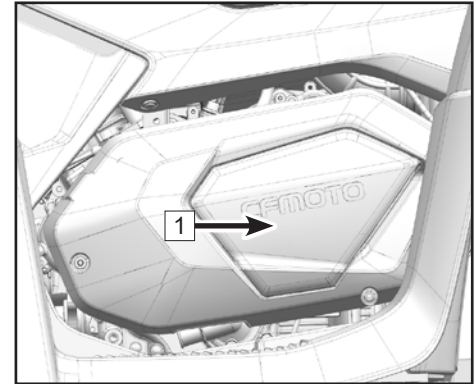

## MAINTENANCE & LUBRICATION

### Engine oil change

1. Place the ATV on a level surface.
2. If the engine was running, wait a sufficient period for the oil to settle and cool.
3. Place an oil pan under the engine to collect the used oil.
4. Remove the engine oil drain bolt **1** and drain the oil from the engine.
5. Place a new sealing washer on the engine oil drain bolt, then tighten the drain bolt to the specified torque (25N•m).

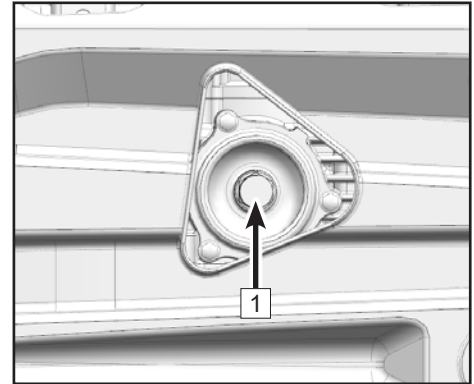

## MAINTENANCE & LUBRICATION

### Oil filter replacement

1. Use wrench to unscrew bolts [1]. Then remove cover [2] and remove oil filter [3].

**Attention:** Confirm cover O-ring [4] is good, then install it into groove of the crankcase correctly.

2. Install new oil filter [3] and use wrench to tighten cover bolts to the specified torque.

**NOTE:** Cover Bolt [1] Torque: 10 N•m

3. If not already installed, install a new drain bolt washer and tighten the oil drain bolt to the specified torque.

**NOTE:** Drain Bolt Torque: 25 N•m

4. Add the specified amount of recommended engine oil, and then insert the engine oil dipstick and tighten it.

### NOTE:

With oil filter cartridge replacement, oil should be added: 2.96qt (2.8 L).

5. Start the engine and warm it up for several minutes. While warming up, check for oil leaks. If an oil leak is found, turn the engine off immediately and check for the cause.
6. Turn the engine off. Recheck the oil level and correct it if necessary.

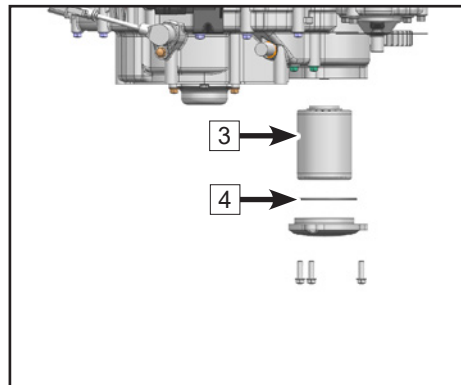
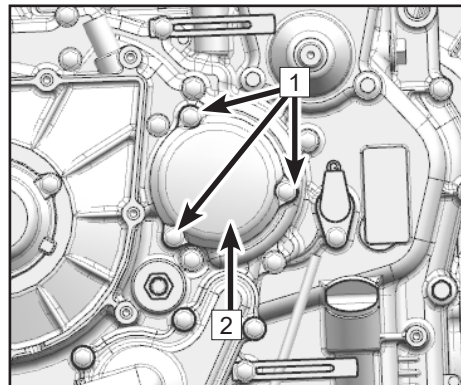

## MAINTENANCE & LUBRICATION

### Engine valve train adjustment

The intake and exhaust valve clearances change with use of the vehicle, which can result in improper fuel/air supply or engine noise. To prevent this, the valve clearances must be adjusted according to the maintenance schedule. This adjustment should be performed by a professional service technician. Contact your dealer for service.

### NOTE

Engine intake valve clearance (cold engine): 0.002 in ~ 0.006 in. (0.06 mm ~ 0.14 mm)

Engine exhaust valve clearance (cold engine): 0.004 in ~ 0.007 in. (0.11 mm ~ 0.19 mm)

### Engine Idle Speed

This vehicle is equipped with an electronic fuel injection system. There are no provisions to adjust engine idle speed. The throttle body is a vital part of the fuel system which requires very sophisticated adjustment, and was set at the factory. If the settings are disturbed, poor engine performance and damage may result. Check engine idle speed for stability and contact your dealer for service if necessary. Contact your dealer in case of an abnormal engine idle condition.

### NOTE

Engine idle speed: 1500 rpm  $\pm$ 150 rpm (engine at operating temperature).

## MAINTENANCE & LUBRICATION

### Gear case oil

The gear cases must be checked for oil leaks before each ride. If an oil leak is found, have your dealer check and repair the ATV.

### Rear case oil measurement

Because of its unique design, draining and filling the gear case is required to produce the correct lubricant level. Refer to 'Rear gear case oil change'.

**NOTE:** Oil filler bolt tightening torque: **18.4 ft-lb. (25 N•m)**.

### Rear gear case oil change

1. Place the machine on a level place.
2. Place a container under the front gear case to catch the oil.
3. Remove oil filler bolt **1** and drain bolt **2** at the bottom of rear gear case, and drain used oil.
4. Install the drain bolt and tighten it to the specified torque.

**NOTE:** Drain bolt tightening torque: 25 N•m

5. Fill the rear gear case with oil.

**NOTE:** Periodic oil change: 200mL

6. Install the filler bolt and tighten it to the specified torque.
7. Check for oil leaks. If an oil leak is found, check for the cause.

**NOTE:** Be sure no foreign material enters the rear gear case.

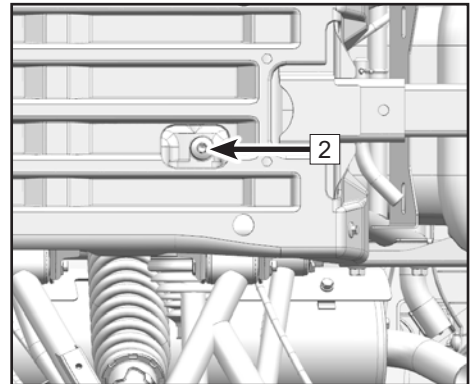
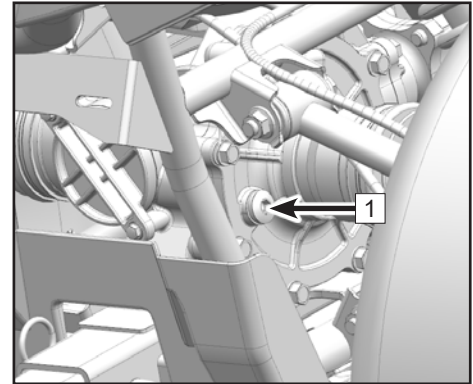

## MAINTENANCE & LUBRICATION

### Front gear case oil measurement

Because of its unique design, draining and filling the gear case is required to produce the correct lubricant level. Refer to 'Front gear case oil change'

**NOTE:** Oil filler bolt tightening torque: **25 N•m**

### Front gear case oil change

1. Place the machine on a level place.
2. Place a container under the front gear case to catch the oil.
3. Remove oil filler bolt and drain bolt [2] at the bottom of front gear case, and drain used oil.
4. Install the drain bolt and tighten it to the specified torque.

**NOTE:** Drain bolt tightening torque: 25 N•m

5. Fill the front gear case with oil.

**NOTE:** Periodic oil change: 230mL

6. Install the filler bolt and tighten it to the specified torque.
7. Check for oil leakage. If oil leakage is found, check for the cause.

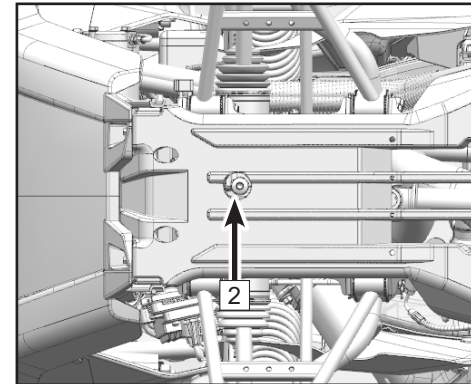
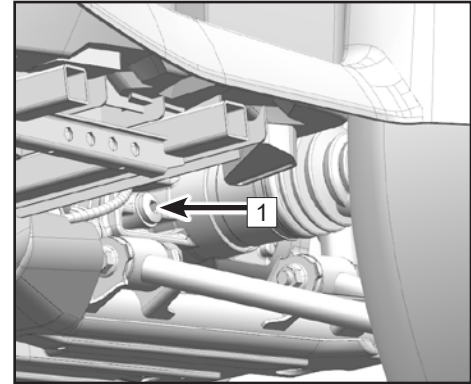

## MAINTENANCE & LUBRICATION

### Front access cover

#### Removal:

Grasp the access cover edge, pull upward to release the grommet pins, then remove the front access cover A by direction of front of vehicle.

Grasp the edge of front top cover B, pull upward to release the grommet pins, then remove the cover B by direction of front of vehicle.

Install: Insert the cover tabs into the corresponding holes on the body, then align the grommet pins and press down.

#### NOTE:

Maintain easy removal cover by applying thin lubricant to the grommet pins occasionally.

Remove front access cover, then inspection and maintenance can be done for the radiator assy, reservoir tank, relay box, and fuse.

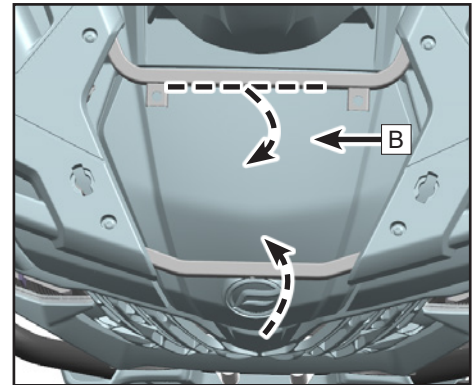
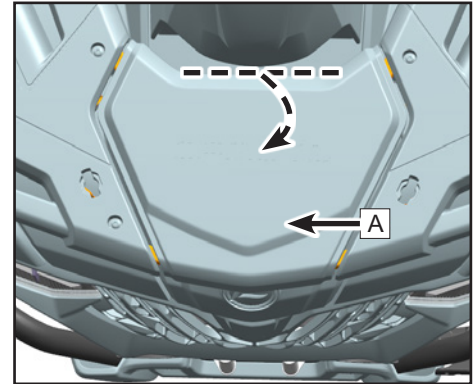

## MAINTENANCE & LUBRICATION

### Cooling system

#### Coolant level check

1. Place the ATV on a level surface.
2. Coolant reservoir **1** is located on the front left of the vehicle. Check the coolant level in the coolant reservoir when the engine is cold as the coolant level will vary with engine temperature.

#### NOTE:

The coolant should be between the upper **3** and lower **4** limit marks.

3. If the coolant is at or below the lower limit mark, remove the reservoir cap **2**, add coolant to the upper limit mark, install the reservoir cap, and then install the panel.

#### NOTE:

Lowest capacity of coolant reservoir: 0.2 L .

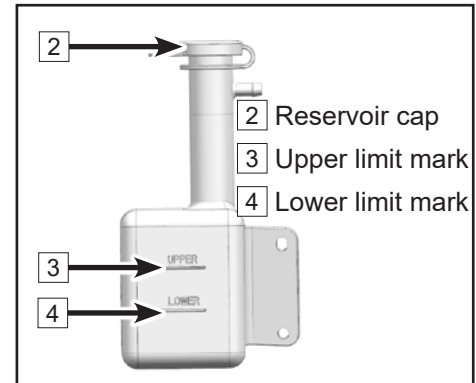
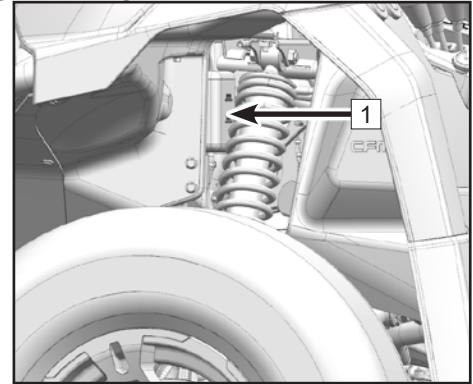

<b>⚠ CAUTION</b>
Hard water or salt water is harmful to the engine. You may use soft water if you cannot get distilled water.

<b>⚠ CAUTION</b>
If water is added, have your dealer check the antifreeze content of the coolant as soon as possible. The radiator fan operation is completely automatic. It is switched on or off according to the coolant temperature in the radiator.

## MAINTENANCE & LUBRICATION

### Changing the coolant

#### **⚠ CAUTION**

After running the engine, never remove the radiator cap immediately. Wait for the engine to cool down before removing the radiator cap. Hot coolant can cause serious burns.

1. Place the ATV on a level surface.
2. Remove the front access cover.
3. Remove the radiator cap [2] .
4. Remove the coolant reservoir cap [1] .
5. Place a container under the engine, and then remove:
  - The small engine left cover [3] .
  - The engine left cover [4] .
  - The coolant drain bolt [5] .

Coolant will begin to drain from the system

6. Disconnect the hose from the coolant reservoir, and drain the coolant into a container.
7. After draining the system, thoroughly flush the system with clean tap water. Allow the water to drain completely from the coolant drain.

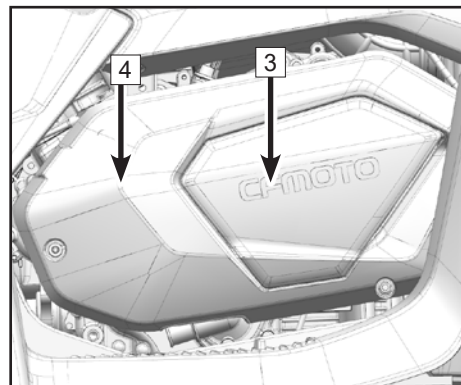
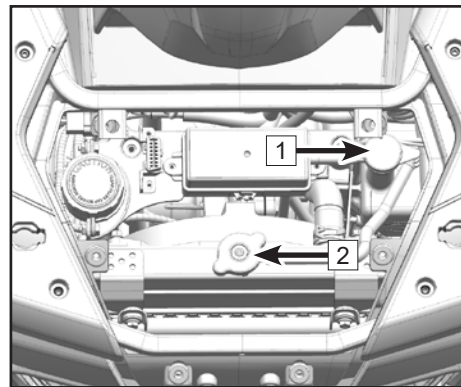

## MAINTENANCE & LUBRICATION

8. Replace the coolant drain bolt washer if it is damaged, then install and tighten the coolant drain bolt, but do not torque to specification.
9. Reinstall the coolant reservoir hose.
10. Fill the recommended coolant into the radiator until it is full.

**NOTE:** When filling coolant, at the same time loosen the coolant drain bolt [5] to draw out potential air bubbles inside the coolant hose until coolant flows out, then tighten the drain bolt to 7.3 ft-lb. (10 N•m).

11. Install the radiator cap.
12. Start the engine and let it idle for several minutes. Stop the engine and allow it to cool. Check the coolant level in the radiator. If it is low, add more coolant until it reaches the top of the radiator. Repeat as necessary.
13. Fill the coolant reservoir with coolant up to the upper limit.
14. Install the coolant reservoir cap and check for coolant leaks. If any leaks are found, have your dealer check the cooling system.
15. Reinstall:
  - The engine left cover. Tighten the fasteners to 10 N•m.
  - The small engine left cover
  - The front access cover

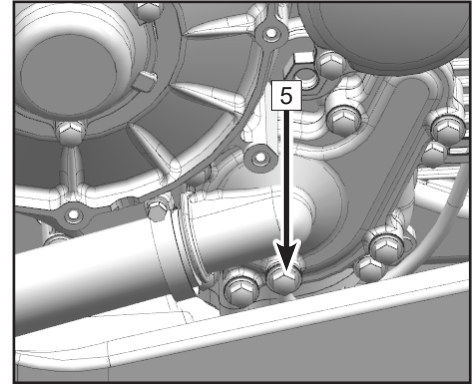

## MAINTENANCE & LUBRICATION

### NOTE

Recommended antifreeze:

Any high quality ethylene glycol antifreeze containing corrosion inhibitors for aluminum engines. CFMOTO recommended coolant freeze protection level: -35°C.

Antifreeze and distilled water mixing ratio: 1:1

Total Coolant Capacity (except coolant reservoir): 2.3 qt. (2.18 L)

Coolant Change (except coolant reservoir): 2.22 qt. (2.1 L)

Coolant reservoir capacity: 0.21 qt. ~ 0.4 qt. (0.2L ~ 0.38 L)

(Lower mark: 0.2 L / Upper mark: 0.38 L)

 <b>WARNING</b>
--

If replace with different coolant, please contact with your dealer to out completely the residual coolant. Different coolant mixture may lead to engine failure.
--

### Cleaning

Cleaning the external surfaces of the radiator if it is covered with mud or debris will ensure it continues to efficiently cooling the engine. Use only low pressure water to clean the radiator. High pressure washers can damage components. Ensure that the water can flow can flow freely through the radiator fins. This is a sign that cooling air will be allow to pass through.

## MAINTENANCE & LUBRICATION

### Axle dust boots

Check the protective boots **1** for holes or wear. If any damage is found, have them replaced by your dealer.

Rear :

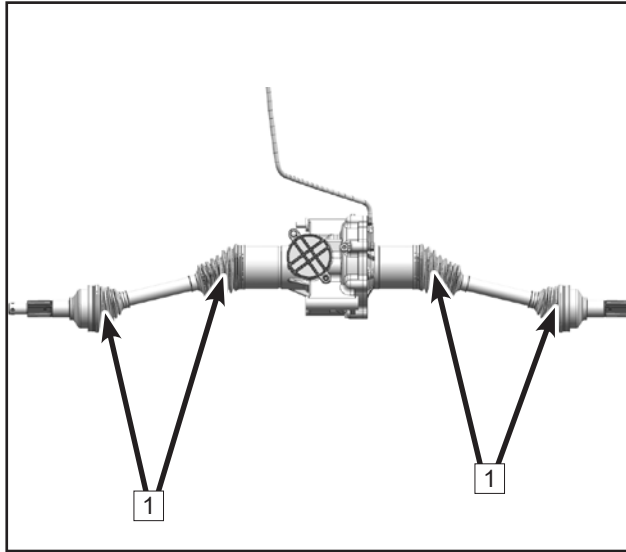

Front:

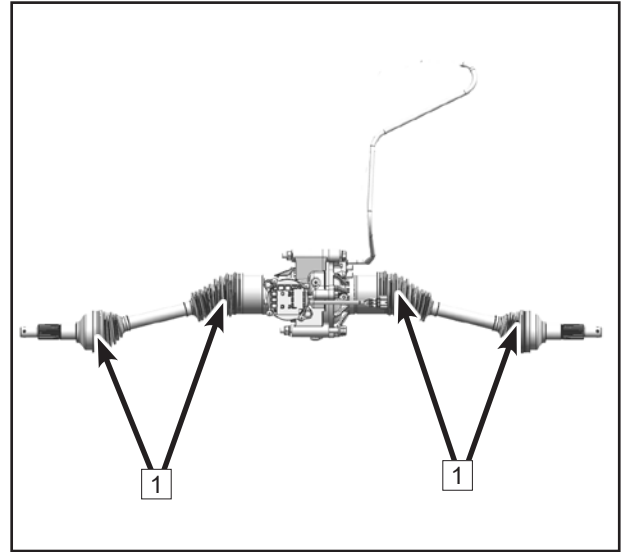

## MAINTENANCE & LUBRICATION

### Spark plug inspection

To access the spark plug, the following components must be removed:

#### Left Deco Panel

Remove the expansion screws **1**.

Remove the bolt **2**.

Remove the cover **3**.

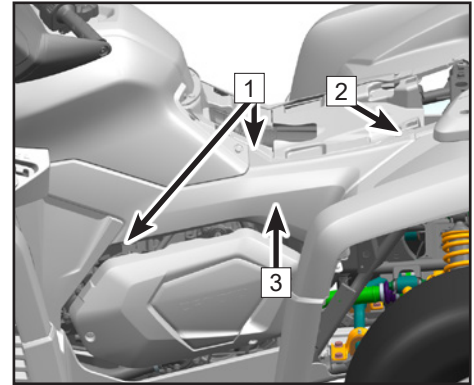

#### Shifter Cover

Remove the screw **4**.

Remove the bolts **5**.

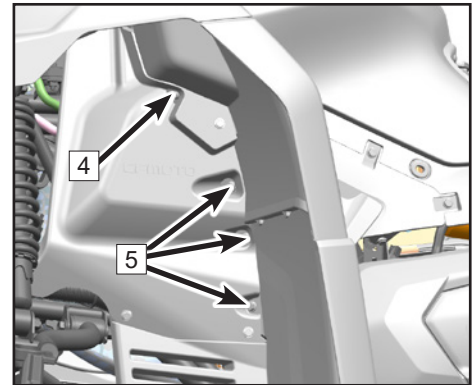

## MAINTENANCE & LUBRICATION

Remove the cover **6**.

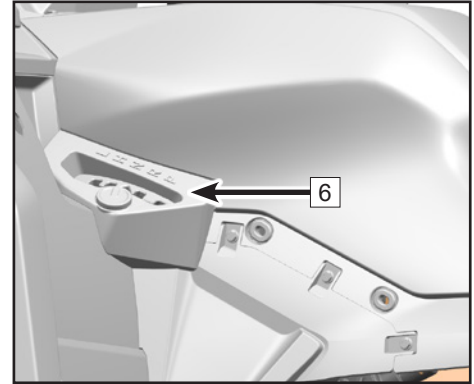

### Lower Side Cover

Remove the bolts **7**.

Remove the left lower side cover **8**.

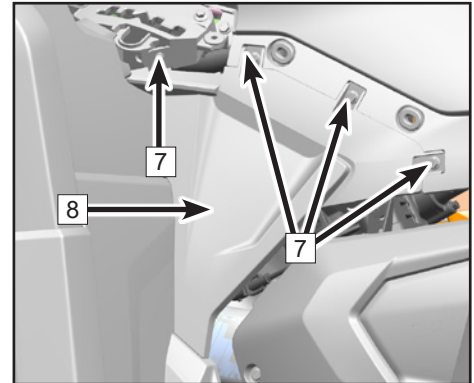

## MAINTENANCE & LUBRICATION

### Removal

Remove the spark plug cap.

Use the spark plug wrench in the tool kit to remove the spark plug.

### Inspection

The spark plug is an important engine component and is easy to inspect. The condition of the spark plug can indicate the condition of the engine. The ideal color on the white insulator around the center electrode is a medium-to-light tan color for a ATV that is being ridden normally. Do not attempt to diagnose such problem yourself. Instead, take your ATV to a dealer. You should periodically remove and inspect the spark plug because heat and deposits will cause the spark plug to slowly break down and erode. If electrode erosion becomes excessive, or if carbon and other deposits are excessive, you should replace the spark plug with the specified plug.

**NOTE:** Specified spark plug: DCPR8E (NGK)

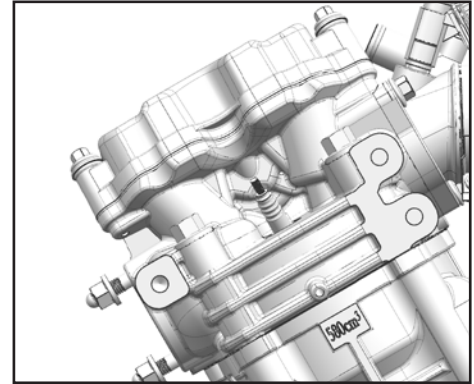

## MAINTENANCE & LUBRICATION

Measure the electrode gap with a thickness gauge, and if necessary, adjust the gap to specification.

**NOTE: Spark plug gap [a]: 0.8 mm ~ 0.9 mm**

### Installation

1. Clean the gasket surface. Wipe off any grime from the threads.
2. Install spark plug and tighten to specified torque.

**NOTE: Spark Plug Torque: 14.8 ft-lb. (20 N•m)**

If a torque wrench is not available when you are installing a spark plug, a good estimate of the correct torque is 1/4 to 1/2 turn past finger tight. Have the spark plug tightened to the specified torque as soon as possible.

3. Install the spark plug cap.
4. Install the panels and shifter cover.

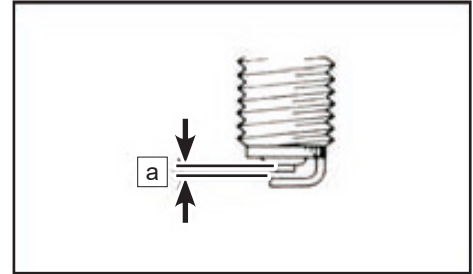

## MAINTENANCE & LUBRICATION

### Spark plug removal to expel water from the engine

If water has been ingested into the engine, it is important to remove the water as soon as possible by removing the spark plug and using the starter system to rotate the engine for a short period to expel water out of the cylinder. Verify that the air box has been drained of water before attempting to expel water.

#### CAUTION

Major engine damage can result if the vehicle if water is ingested into the engine. Have the vehicle serviced by your dealer promptly if your vehicle becomes immersed or stalls in water that exceeds the footrest level. It is important to contact your dealer for service before starting the engine if water has been ingested. Water inside the engine can cause a 'hydraulic lock' effect that can damage the starter and engine components. The engine oil should be checked for water contamination. Drain and refill with new engine oil if water is found in the crankcase.

## MAINTENANCE & LUBRICATION

### Air filter element

Always check and change the engine oil at the intervals outlined in the Maintenance Schedule. The air filter element should be cleaned more often if the machine is operated in extremely dusty or wet areas. There is a check hose **1** at the bottom of the air filter housing. If dust or water can be viewed in this hose, empty the hose and clean the air filter housing thoroughly. If the vehicle was submerged, please contact your local dealer to check for water inside the engine crankcase.

### Air filter maintenance

1. Remove the seat.
2. Remove the upper protector of air filter **2**.
3. Remove the cover spring clips **3** and bolt **4**.
4. Remove the filter housing cover **5**.
5. Loosen the air filter clamp **6** and remove the foam pre-filter **7**.
6. Remove the foam pre-filter **7** from the air filter.
7. Wash the foam pre-filter gently with soap and water, and allow it to completely dry.
8. Inspect the paper air filter and verify it is okay to reinstall. Softly brush off accumulated dust if necessary. Install a new filter as necessary.
9. Install the pre-filter onto the air filter. Apply a thin film of lubricant on the inside diameter of the air filter rubber seal.

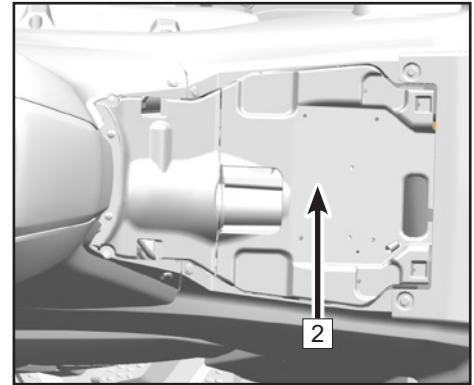
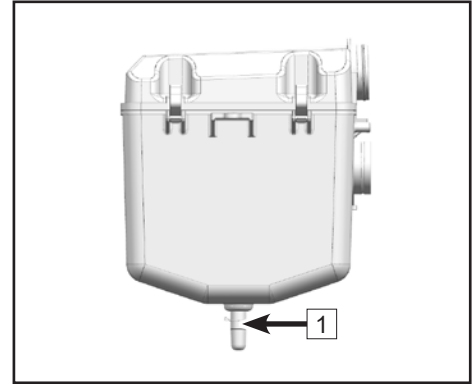

## MAINTENANCE & LUBRICATION

10. Install the air filter and clamp onto the air filter housing inlet. Tighten the clamp securely.
11. Reinstall the air filter housing cover and spring clips. Verify the cover is installed correctly and is sealing properly.
12. Reinstall the decorative cover assembly. Ensure the grommets are engaged and secure.

**NOTE:** Do not wash paper air filters, or use compressed air to clean the filter media.

7. Install the pre-filter onto the air filter. Apply a thin film of lubricant on the inside diameter of the air filter rubber seal.
8. Install the air filter and clamp onto the air filter housing inlet. Tighten the clamp securely.
9. Reinstall the air filter housing cover and spring clips. Verify the cover is installed correctly and is sealing properly.

### NOTE

The air filter element should be cleaned every 50 hours. It should be cleaned and lubricate more often if the machine is operated in extremely dusty areas. Each time air filter element maintenance is performed, check the air inlet to the air filter box for obstructions. Check the air filter element rubber joint to the throttle body and manifold fittings for an airtight seal. Tighten all fittings securely to avoid the possibility of unfiltered air entering the engine.

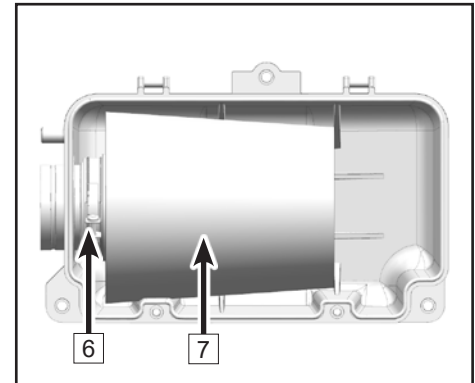
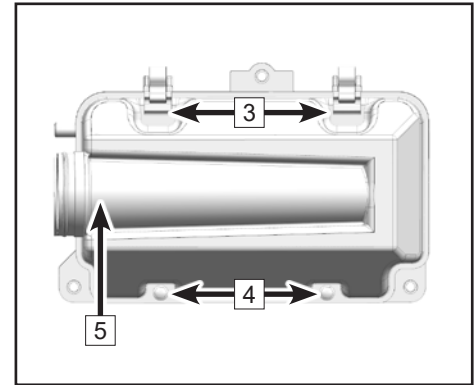

## MAINTENANCE & LUBRICATION

### Drying the air filter housing after submersion

If water has been ingested into the air filter housing, Drain the air filter housing, remove the air filter, and thoroughly dry the components. Do not use compressed air. Contact your dealer if vehicle performance issues exist.

#### CAUTION

Do not operate the engine without an air filter element. Unfiltered air will enter into the engine and cause engine wear and damage. Driving without an air filter will also decrease performance and can lead to engine overheating.

#### CAUTION

Major engine damage can result if the vehicle if water has been ingested into the air filter housing, and engine. Have the vehicle serviced by your dealer promptly if your vehicle becomes immersed or stalls in water that exceeds the footrest level. It is important to contact your dealer for service before starting the engine, as water may have been ingested in the air box and engine.

## MAINTENANCE & LUBRICATION

### Spark Arrestor

Clean spark arrestor while muffler and exhaust are in normal temperature.

1. Remove nut **1**.
2. Remove spark plug arrestor **2** from muffler.
3. Tap the tailpipe lightly, and then use a wire brush to remove any carbon deposits **3** from the spark arrestor portion of the tailpipe.
4. Insert the tailpipe into the muffler and align the bolt holes.
5. Install and tighten the bolts.

#### **WARNING**

When cleaning the spark arrestor: Always let the exhaust system cool prior to touching exhaust components. Do not start the engine when cleaning the exhaust system.

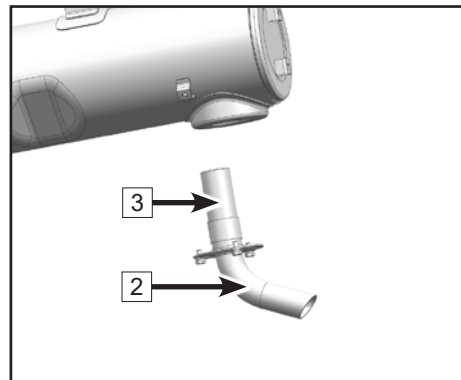
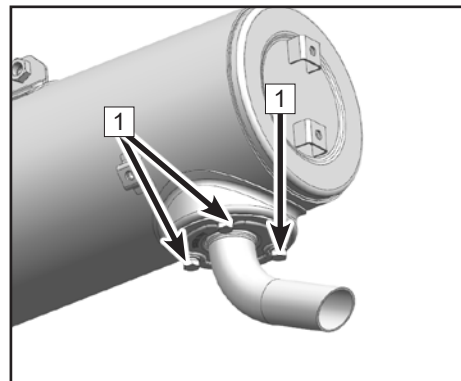

## MAINTENANCE & LUBRICATION

### Throttle body adjustment

The throttle body is a vital part of the engine and requires very sophisticated adjustment. Most adjusting should be left to your dealer who has the professional knowledge and experience to do so. However, the idling speed may be performed by the owner as a part of the usual maintenance routine. The throttle body was set at the factory after many tests. If the settings are disturbed by someone without sufficient technical knowledge, poor engine performance and damage may result. Check idle for stability and contact your dealer for service if necessary.

### Engine idle adjustment:

 <b>WARNING</b>
--

this vehicle is equipped with EFI system, and no need to adjust idle, or performance will be affected. Contact your dealer in case abnormal idle.
---

### NOTE

Engine idle: 1500r/min±150r/min (Heated engine)

### ●Engine air inlet/outlet valve clearance adjustment

The correct valve clearance changes with use, resulting in improper fuel/air supply or engine noise. To prevent this, the valve clearance must be adjusted regularly. This adjustment however, should be left to a professional service technician.

## MAINTENANCE & LUBRICATION

### Brakes

#### Front brake pad inspection

Inspect the front brake pads and discs for damage and wear. If the pad thickness **A** is less than 1.5mm or the disc thickness **B** is less than 3.0mm, have your dealer replace them. Replacement of brake components requires professional knowledge. These procedures should be performed by your dealer.

#### NOTE

Wheels must be removed to check brake pads.

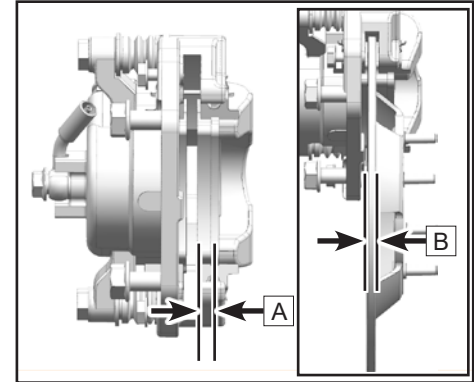

#### **⚠ CAUTION**

After servicing:

- Make sure the brakes operate smoothly and that the lever free play is correct.
- Make sure the brakes do not drag and the brake operation is not spongy.
- All air is bled from the brake system.

## MAINTENANCE & LUBRICATION

### Rear brake pad inspection

Inspect the brake pads and rear brake discs for damage and wear. If the pad thickness **A** is less than 1.5mm or the disc thickness **B** is less than 4.0mm, then have your dealer replace them. Replacement of brake components requires professional knowledge. These procedures should be performed by your dealer.

#### CAUTION

After servicing:

- Make sure the brakes operate smoothly and that the lever free play is correct.
- Make sure the brakes do not drag and the brake operation is not spongy.
- All air is bled from the brake system.

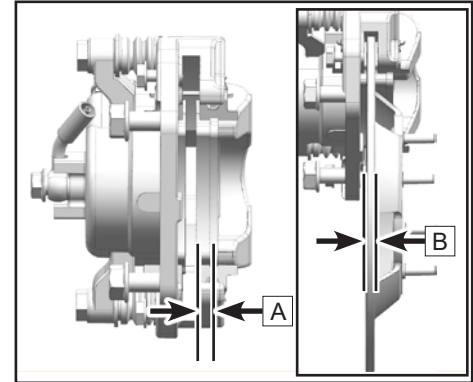

## MAINTENANCE & LUBRICATION

### Brake fluid level inspection

Before riding, check that the brake fluid levels are above the lower mark and replenish whenever necessary. Insufficient brake fluid may let air enter the brake system, possibly causing the brakes to become ineffective. The front brake fluid master cylinder reservoir level **A** is located on the right handlebar. The rear brake fluid master cylinder reservoir **B** is under the front rack access panel.

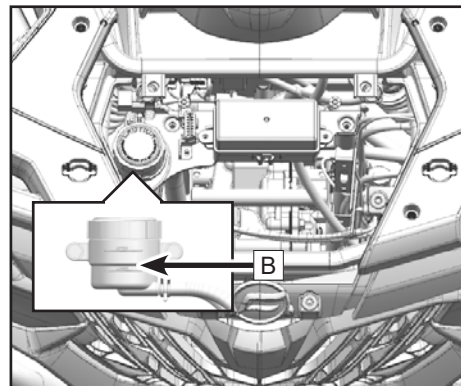
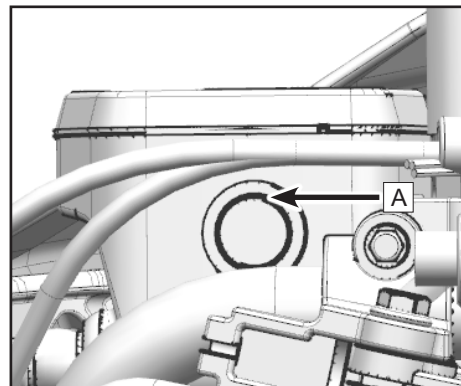

## MAINTENANCE & LUBRICATION

### Observe these precautions:

1. When checking the fluid level, make sure the top of the master cylinder reservoir is level by turning the handlebars.
2. Use only the designated quality brake fluid. Otherwise, the rubber seals may deteriorate, causing leakage and poor brake performance.
3. Recommended brake fluid: DOT 4.
4. Refill with the same type of brake fluid. Mixing fluids may result in a harmful chemical reaction and lead to poor brake performance.
5. Be careful that water does not enter the master cylinder reservoir when refilling. Water will significantly lower the boiling point of the fluid and may result in vapor lock.
6. Brake fluid may deteriorate painted surfaces or plastic parts. Always clean up spilled fluid immediately.
7. Have your dealer check the cause if the brake fluid level goes down.

### Brake fluid change

Complete fluid replacement should be done only by trained service personnel. Have your dealer replace the following components during periodic maintenance or when they are damaged or leaking.

Replace the oil seals every two years.

Replace the brake hoses every four years.

## MAINTENANCE & LUBRICATION

### Front brake lever freeplay

The front brake lever **A** should have zero in. (zero mm) free play of at the lever end. If free play is present, have your dealer check the brake system.

#### **⚠ DANGER(After servicing):**

- Make sure the brakes operate smoothly and that the free play is correct.
- Make sure the brakes do not drag. Make sure the brakes are not spongy.
- All air must be bled from the brake system. Servicing of brake components requires professional knowledge. These procedures should be performed by your dealer.

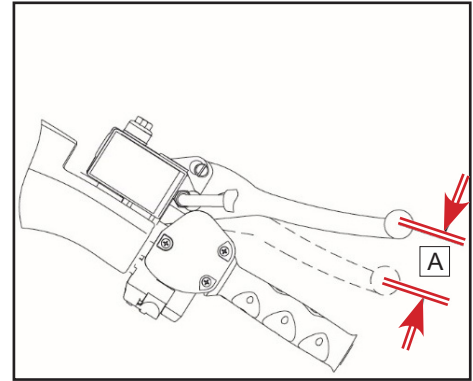

## MAINTENANCE & LUBRICATION

### Foot brake pedal hight adjustment

#### NOTE

The top of the brake pedal should be positioned 95 mm ~ 100 mm above the top of the footrest. If it is not, have your dealer to adjust it.

#### **⚠ DANGER**

After servicing:

- Make sure the brakes operate smoothly and that the freeplay is correct.
- Make sure the brakes do not drag.
- All air must be bled from the brake system. Replacement of brake components requires professional knowledge. These procedures should be performed by your dealer.

### Foot brake light switch

Check switch assembly or cable is properly fixed in case of brake light failure.

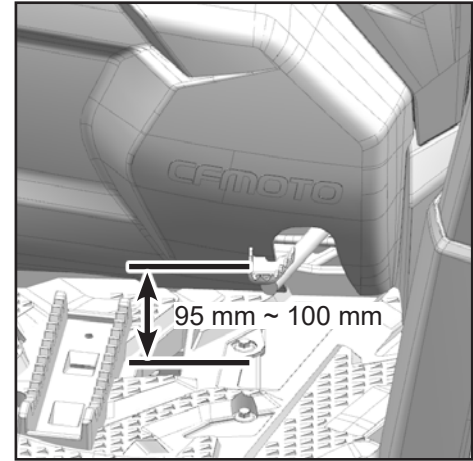

## MAINTENANCE & LUBRICATION

### Control Cables

#### **WARNING**

Inspect cables frequently. Replace damaged cables. Lubricate the inner cables and the cable ends. If the cables do not operate smoothly, ask your dealer to replace them.

#### **NOTE**

Recommended lubricant: SAE 10W/30

#### **Suspension Pivot Lubrication**

Lubricating rear stabilizer bar.

Add lubricating grease into grease nipple **1** with oil gun until oil outflowing from bushing.

#### **NOTE**

There are 2 grease nipples on rear stabilizer bar, they are symmetrical in left and right.

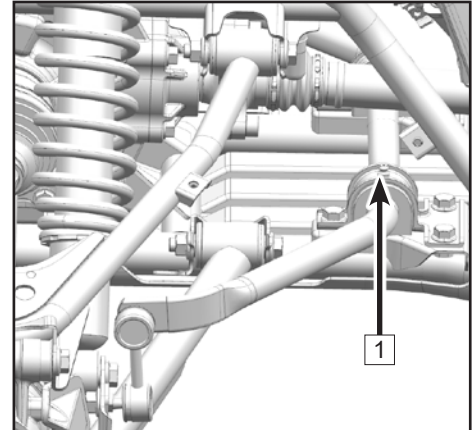

## MAINTENANCE & LUBRICATION

### Suspension

#### Front suspension lubrication

The front suspension of the vehicle contains components that require no maintenance or lubrication. Ensure the components are cleaned regularly, and are not loose or damaged before operating the vehicle.

#### Rear suspension lubrication

Lubricate the upper and lower pivots of the rear axles:

1. Remove the rear wheels **1**.
2. Add grease into the grease nipples **2** at the upper and lower pivots with a grease gun.
3. Reinstall the rear wheels. Torque the fasteners to specification.

#### NOTE

Recommended lubricant: All Season Grease

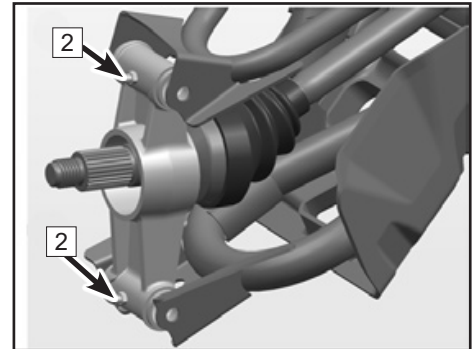
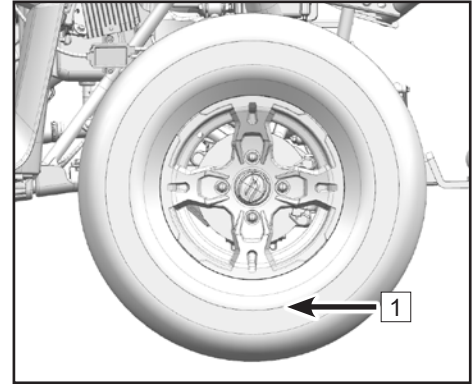

## MAINTENANCE & LUBRICATION

### Front and rear suspension adjustment

The front and rear suspension spring preload can be adjusted to suit the rider's weight and riding conditions.

#### NOTE

When adjusting the rear shock absorbers, the rear wheels need to be removed.

Adjust the spring preload as follows.

To increase the spring preload, turn the adjusting ring **1** in direction **a**.

To decrease the spring preload, turn the adjusting ring **1** in direction **b**.

Standard preload position: **C**

A- Minimum (soft)

E- Maximum (hard)

#### NOTE

A special wrench **2** (if not supplied in tool kit) can be obtained at a dealer to make this adjustment.

Always adjust the shock absorbers on the left and right sides to the same setting.

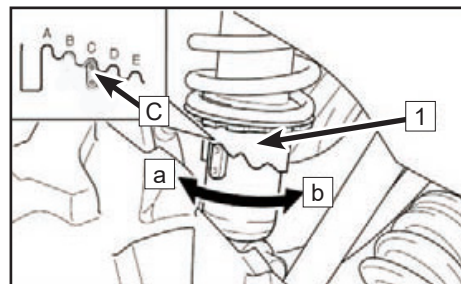

## MAINTENANCE & LUBRICATION

### Wheel and Tires

#### Removal and installation

##### Removal

1. Loosen the wheel nuts 1.
2. Elevate the ATV and place a suitable stand under the frame.
3. Remove the nuts from the wheel.
4. Remove the wheel.

##### Installation:

1. Install the wheel and the nuts.

#### NOTE

- Tapered nuts are used for both the front and rear wheels. Install the nut with its tapered side towards the wheel.
  - The arrow mark on the tire must point toward the rotating direction of the wheel.
2. Lower the ATV so that the wheel is on the ground.
  3. Tighten the wheel nuts to the specified torque.

#### NOTE

Wheel nut torque:       Front: (70 N•m ~ 80 N•m);  
                                  Rear: (70 N•m ~ 80 N•m)

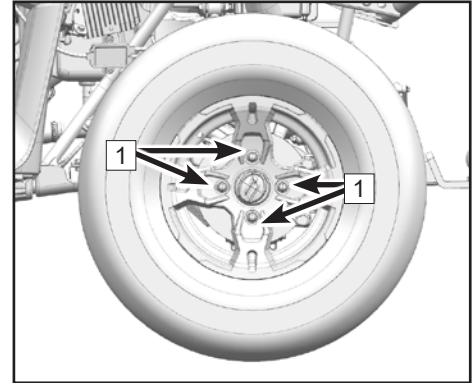

## MAINTENANCE & LUBRICATION

### Tire pressure

Inspect the tire pressure before operation:

Front: 6.5 psi (45 kPa)

Rear: 6.5 psi (45 kPa)

### Tread depth

Inspect the tread depth regularly and replace the tires if the minimum tread depth is less than:

Minimum tread depth: 3/32 in. (3.0 mm)

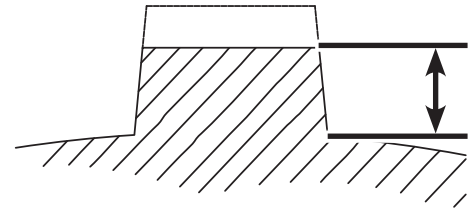
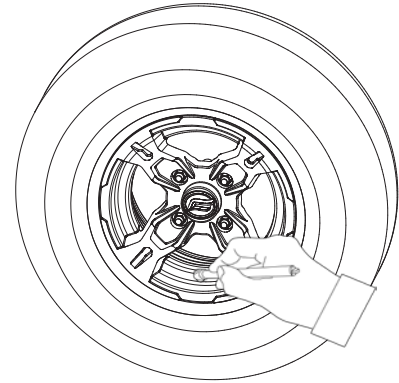

## MAINTENANCE & LUBRICATION

### Battery

This vehicle is equipped with a 12 volt / 30 Amp hour, sealed low-maintenance battery, which is located under the seat. Therefore, it is not necessary to check the electrolyte or add distilled water to the battery. If the battery seems to have discharged, consult your dealer. Verify that the battery connections are clean and secured during routine maintenance.

#### Battery maintenance guidelines:

- If the vehicle will not be used for a month or longer, remove the battery and store it in a cool, dry place. Completely recharge the battery before reinstallation.
- A special battery charger (constant low voltage/ampere) is required for recharging low maintenance batteries. Using a conventional battery charger may shorten the battery life.
- Always make sure the cable connections are the correct polarity when reinstalling the battery. RED ('+' positive) / Black ('-' negative). Always disconnect the RED ('+' positive) cable last during removal, and reconnect it first during installation.
- Corroded battery connections can be cleaned with a mixture of baking soda and water.

#### WARNING

Avoid contact with skin, eyes or clothing, and always shield eyes when working near batteries. Keep out of reach of children. Keep batteries away from sparks, flames, cigarettes or other sources of ignition. Ventilate the area when charging or using in a closed space.

#### Battery acid antidote:

EXTERNAL: Flush with water.

INTERNAL: Get prompt medical attention.

EYES: Flush with water for 15 minutes and get prompt medical attention.

## MAINTENANCE & LUBRICATION

### Battery Disassembly

Turn off all electrical parts and the engine before disassembly.

#### Disassembly (The L model)

Remove bolt [1];

Remove the rear seat mounting bracket [2];

Remove the belt [3] and electrode cover [4];

Remove the fixing bolt of battery negative wire together with the wire;

Remove the fixing bolt of battery positive wire together with the wire;

Take out the battery [5].

#### Assembly (The L model)

Mount the battery [1] in place;

Mount the positive wire onto the battery positive bolt;

Mount the negative wire onto the battery negative bolt;

Mount the belt [2] and electrode cover [3];

Mount the rear seat mounting bracket [4];

Mount the bolt [5].

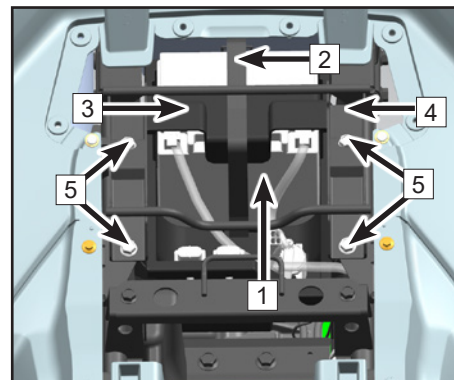
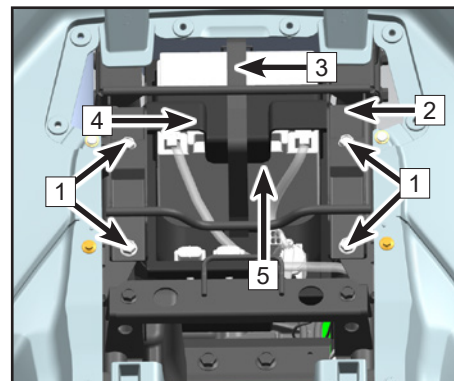

## MAINTENANCE & LUBRICATION

### Assembly (The L model)

Mount the battery **1** in place.

Mount the positive wire onto the battery positive bolt.

Mount the negative wire onto the battery negative bolt.

Mount the belt **2** and electrode cover **3**.

Mount the rear seat mounting bracket **4**.

Mount the bolt **5**.

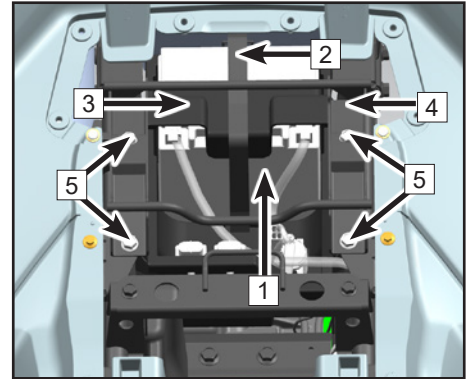

Mount the deco panel **6**.

Mount the expansion screws **7**.

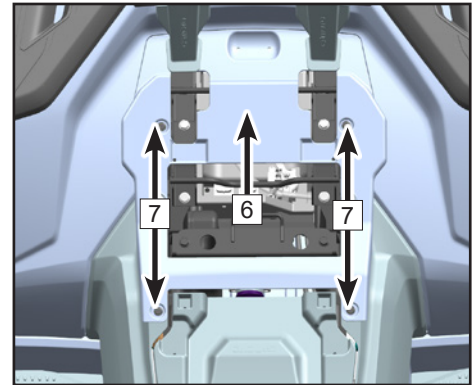

## MAINTENANCE & LUBRICATION

### Disassembly (The S model)

- Remove the expansion screw [1];
- Remove the upper cover of rear fender [2];
- Remove the bolt [3];
- Remove the front seat assembling bracket [4];
- Take out the belt [5] and electrode protector [6];
- Remove the fixing bolt of battery negative wire together with the wire;
- Remove the fixing bolt of battery positive wire together with the wire;
- Take out the battery [7].

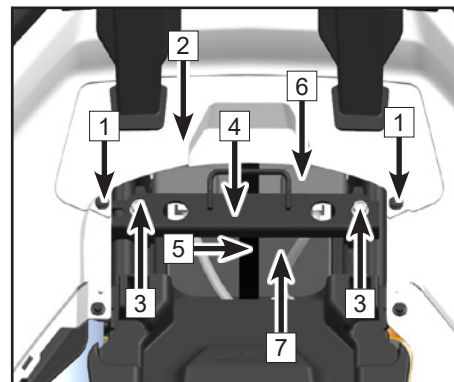

### Assembly (The S model)

- Mount the battery [1] in place;
- Mount the positive wire onto the battery positive bolt;
- Mount the negative wire onto the battery negative bolt;
- Mount the belt [2] and electrode cover [3];
- Mount the rear seat mounting bracket [4];
- Mount the bolt [5];
- Mount the upper cover of rear fender [6];
- Mount the expansion screw [7];

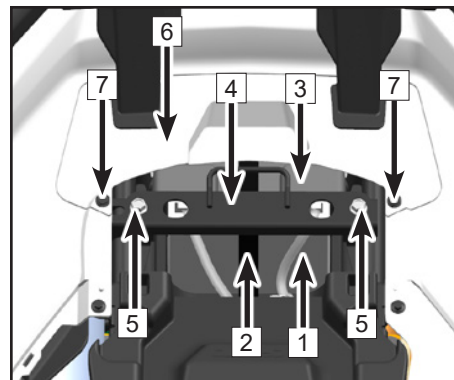

## MAINTENANCE & LUBRICATION

### Fuse and Relay replacement

1. Relay / Fuse box **1** is located under the front access cover. Main fuse 30A **2** and EPS fuse 40A **3** are located under the seat.
2. If a fuse is blown, turn off the main switch and install a new fuse of the specified amperage. Test by turning on main power and switches. If the fuse immediately blows again, consult your dealer.

#### **⚠ CAUTION**

Always use a fuse of the specified rating.

Never use conductive material in place of the proper fuse.

#### **⚠ CAUTION**

To prevent an accidental short-circuit, turn off the main switch when checking or replacing fuses. Always use a fuse with the correct specified rating. Never use conductive material in place of the proper fuse.

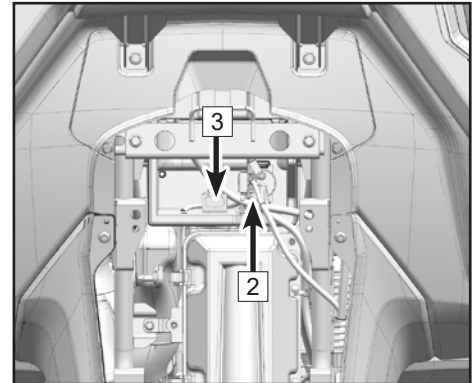
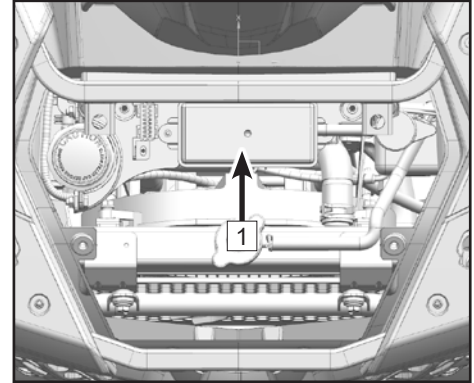

## MAINTENANCE & LUBRICATION

### Relay / Fuse Box

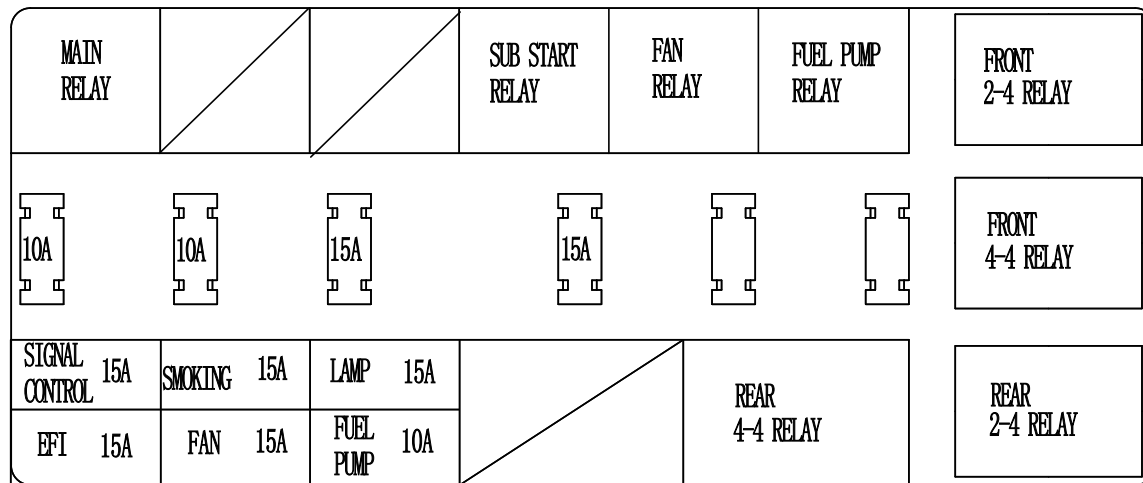

## MAINTENANCE & LUBRICATION

### Electrical

**⚠ WARNING**

To prevent accidental short-circuit, turn off the main switch when checking or replacing a fuse.

### Headlight bulb replacement

**NOTE:**

Both headlight and taillight assy are LED lights, which cannot be repaired if damaged or failed. Please have your dealer replace the entire assembly when the LED light is damaged or failed.

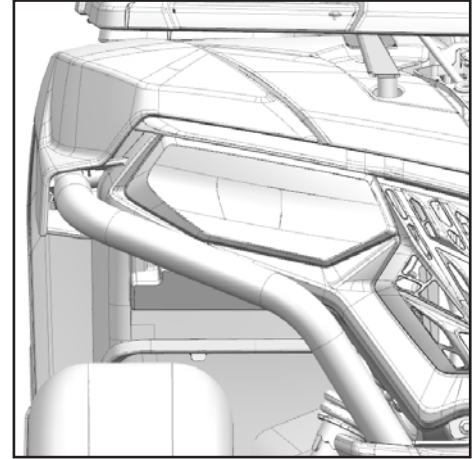

## MAINTENANCE & LUBRICATION

### Headlight beam adjustment

**⚠ WARNING**

It is advisable to have your dealer make this adjustment. Turn the adjusting screws can raise or lower the beam.

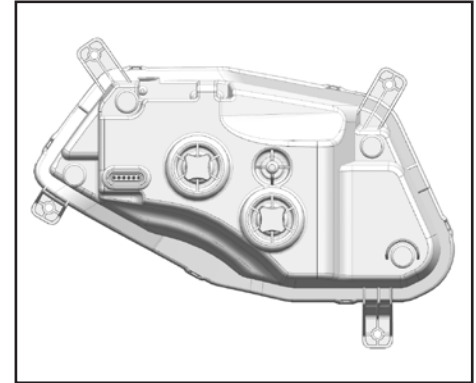

### Tail/brake light and License plate lamp replacement:

They can not be replaced separately. Replace the whole light as necessary.

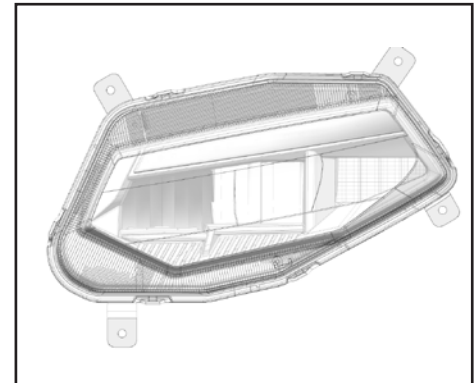

## MAINTENANCE & LUBRICATION

### Vehicle immersion

 **WARNING**

If your vehicle becomes immersed, major engine damage can be resulted if the machine is not thoroughly inspected. Take the vehicle to your dealer before starting the engine. For example,if engine is not properly handled after immersion,starting will damage the engine.

## MAINTENANCE & LUBRICATION

### Cleaning and Storage

#### Washing the Vehicle

Keeping your vehicle clean will not only improve its appearance, but it can also extend the life of various components. With a few precautions, your vehicle can be cleaned much like an automobile:

- The best and safest way to clean your vehicle is with a garden hose and a pail of mild soap and water. Harsh detergents may deteriorate rubber components.
- Use a professional type washing mitten, cleaning the upper body first and the lower parts last.
- Pay special attention that the cooling system radiator and axle boots are thoroughly cleaned of all dirt and debris.
- Rinse with water frequently and dry the vehicle with a chamois to prevent water spots.
- Lubricate all pivot points immediately after washing.
- Allow the engine to run for a while to evaporate any water that may have entered the engine air intake or exhaust system.

CFMOTO does not recommend the use of a high pressure type car wash system for washing your vehicle, as water can be forced past seals and damage decals. If a high pressure system is used, exercise extreme care to avoid water damage to the decals, wheel bearings, transmission seals, body panels, brakes, warning labels, air filter intake system and electrical system. Ensure water is not allowed to enter into the air filter or CVT housing. If warning and safety labels are damaged, contact your dealer for a replacement.

#### Waxing the Vehicle

Your vehicle can be waxed with any non-abrasive automotive paste wax. Avoid the use of harsh cleaners since they can scratch the body finish.

## MAINTENANCE & LUBRICATION

### CAUTION

**Certain products, including insect repellants and other chemicals, will damage plastic surfaces. Use caution when using these products near plastic surfaces.**

### **Perform Repairs**

Make necessary repairs to your vehicle before storing to prevent further damage the next time you operate it.

### **Check the Tires**

Inspect the tire treads and overall condition. Set the tires to the specified air pressure.

### **Oil and Filter**

Warm the engine, then stop the engine and change the oil and filter.

### **Air filter/ Air box**

Inspect and clean or replace air filter. Clean the air box and the sediment tube.

### **Check Fluid Levels**

Inspect the following fluid levels and change if necessary:

- Front gear case
- Rear gear case
- Brake fluid (change every two years or as required if fluid looks dark or contaminated)
- Coolant (change every two years or as required if coolant looks contaminated)
- Fuel Level (add fuel stabilizer according to the product label directions)

## MAINTENANCE & LUBRICATION

### Stabilize the Fuel

Fill the fuel tank with fresh fuel that has been treated with fuel stabilizer according to the product label directions. Do not allow untreated fuel to remain in the tank longer than 30 days, as the fuel begins to degrade and can cause damage to the fuel system components.

### Battery Storage

- Remove the battery from the vehicle and ensure that it is fully charged before placing it in storage. Protect the battery from freezing temperatures, which can damage the battery.

### Lubricate

Inspect all cables and lubricate with cable lubricant according to the product label directions. Grease the vehicle lubricating points with all season grease.

### 'Fog' the Engine

- Tilt the cargo box to access the spark plug(s).
- Remove the spark plug(s), rotate the piston to the bottom of its stroke, and pour approximately 15mL~20mL of engine oil into the opening.

### NOTE:

Do this carefully! If you miss the spark plug hole, oil will drain from the spark plug cavity, and appear to be an oil leak. To access the spark plug hole, use a section of clean hose and a small plastic squeeze bottle filled with the pre-measured amount of oil.

- Reinstall the spark plug(s). Torque the spark plug to specification.
- Turn engine over several times slowly. Oil will be forced in and around the piston, piston rings and the cylinder will be coated with a protective film of fresh oil.

## **MAINTENANCE & LUBRICATION**

- Reinstall the spark plug(s), cap(s), and side panel.

### **NOTE:**

Starting the engine during the storage period will disturb the protective film created by fogging. Corrosion could occur. Never start the engine during the storage period.

### **Storage Area And Covering**

Support the vehicle with stands under the frame with the tires 30mm~40mm (1/2in) off the ground. Be sure the storage area is well ventilated, and cover the machine with an approved cover.

### **NOTE:**

Do not use covers made of plastic or coated materials. They do not allow enough ventilation to prevent condensation, and may promote corrosion and oxidation.

## CLEANING & STORAGE

### Transporting the Vehicle

Follow these procedures when transporting the vehicle:

- Turn off the engine and remove the key to prevent loss during transporting.
- Ensure the fuel cap is installed correctly and secure.
- Ensure the seat is installed correctly and secure.
- Place the gear into any position except the parking position, and block the front and rear wheels to prevent the vehicle from moving.

<b>⚠ CAUTION</b>
------------------

<b>Never transport with the gear selector in the parking position.</b>
--

<b>Damage to the engine and transmission may result.</b>
--

- Secure both the front and rear of the vehicle frame to the transport to prevent the vehicle from sliding or moving.

## CLEANING & STORAGE

### Vehicle Issue Diagnosis

This section is intended to guide an average owner to simple items that could cause operating problems. Diagnosis of vehicle issues may require the experience of a dealership technician. Please contact your dealer if a solution is not apparent.

#### Engine doesn't turn over

Possible Cause	Solution
Blown fuse	Reset or replace the fuse
Low battery voltage	Recharge battery to 12.8 Vdc – Confirm battery state of health
Loose battery connections	Check all connections and tighten if necessary
Loose starter system electrical connections	Check all connections and tighten if necessary
Engine stop switch	Check function
Start circuit not complete – transmission in gear	Press foot brake or shift transmission to neutral or parking position.

#### Engine pings or knocks

Possible Cause	Solution
Poor quality or low octane fuel	Replace with minimum 95(ROn) or E10 octane unleaded fuel
Incorrect ignition timing.	See your dealer
Incorrect spark plug gap or heat range	Set spark plug gap to specs or replace plugs

## CLEANING & STORAGE

### Engine stops or loses power

Possible Cause	Solution
Overheated engine	Clean radiator screen and external core; clean engine exterior; See your dealer
Out of fuel	Refuel with minimum 95(ROn) or E10 octane unleaded fuel
Kinked or plugged fuel tank vent line	Inspect and replace; See your dealer
Water present in fuel	Replace with new fuel
Fouled or defective spark plugs	Inspect and clean or replace spark plug
Worn or defective spark plug wires	See your dealer
Incorrect spark plug gap or heat range	Set gap to specs or replace plug
Loose ignition connections	Check all connections and tighten
Low battery voltage	Recharge battery to 12.8 Vdc; check charging system – Confirm battery health
Clogged air filter	Inspect and replace as necessary
Reverse speed limiter malfunction	See your dealer
Electronic throttle control malfunction	See your dealer
Other mechanical failure	See your dealer

## CLEANING & STORAGE

### Engine turns over, Fails to start

Possible Cause	Solution
Engine turns over, Fails to start	Refuel
Clogged fuel filter	Inspect and replace as necessary
Water is present in fuel	Replace with 95(RON) or E10 minimum octane unleaded fuel
Fuel pump is inoperative	Inspect pump and fuse; Replace as necessary
Old or non-recommended fuel	Replace with 95(RON) or E10 minimum octane unleaded fuel
Possible Cause	Solution
Fouled or defective spark plugs	Inspect spark plugs, replace if necessary
No spark to spark plug	Inspect spark plugs, verify stop switch is on
Crankcase filled with water or fuel	Immediately see your dealer
Clogged air filter	Inspect and replace as necessary; Replace spark plugs as necessary
Clogged fuel injector	See your dealer
Low battery voltage	Recharge battery to 12.8 Vdc – Confirm battery health
Mechanical failure	See your dealer

## CLEANING & STORAGE

### Engine backfires

Possible Cause	Solution
Weak spark from spark plugs	Inspect and replace spark plugs as necessary
Incorrect spark plug gap or heat range	Set gap to specs or replace plugs
Old or non-recommended fuel	Replace with minimum 95(RON) or E10 octane unleaded fuel
Incorrectly installed spark plug wires	See your dealer
Incorrect ignition timing	See your dealer
Mechanical failure	See your dealer
Speed limiter malfunction	See your dealer

### Engine runs irregularly, stalls or misfires

Possible Cause	Solution
Fouled or defective spark plugs	Inspect and replace spark plugs as necessary
Worn or defective spark plug wires	See your dealer
Incorrect spark plug gap or heat range	Set gap to specs or replace plugs
Loose electrical connections	Check all connections and tighten
Water present in fuel	Replace with new fuel
Low battery voltage	Recharge battery to 12.8 Vdc; Check charging system
Kinked or plugged fuel tank vent line	Inspect and replace
Incorrect fuel	Replace with 95(RON) or E10 minimum octane unleaded fuel
Clogged air filter	Inspect and replace as necessary; Replace spark plugs as necessary
Reverse speed limiter malfunction	See your dealer
Electronic throttle control malfunction	See your dealer

## CLEANING & STORAGE

Possible Cause	Solution
Other mechanical failure	See your dealer
Possible Lean or Rich fuel mixture	See your dealer
Low or contaminated fuel	Add or change fuel, clean the fuel system
Low octane fuel	Replace with minimum 95(RON) or E10 octane unleaded fuel
Clogged fuel filter	Replace filter
Fuel is very high octane	Replace with minimum 95(RON) or E10 octane unleaded fuel

## CLEANING & STORAGE

### EFI Malfunction Indicator Light

The Electronic Fuel Injection system on your vehicle contains a self-diagnostic feature that will illuminate the malfunction indicator light (MIL) if it detects a problem. When this indicator is on, the fault code will display on the dashboard directly, record the fault code and contact your dealer for diagnosing. Your dealer has the EFI tool required to diagnose, repair and clear trouble codes.

During normal operation, the EFI indicator will be off.

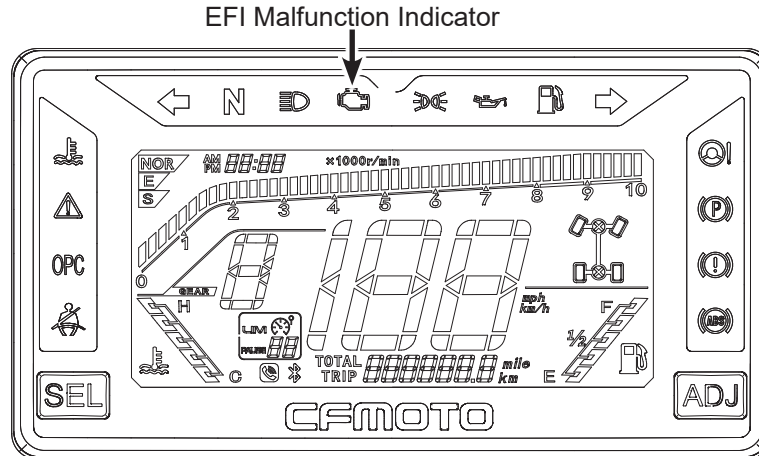

## CLEANING & STORAGE

### EPS Malfunction Indicator Light

The Electronic Power Steering system on your vehicle contains a self-diagnostic feature that will illuminate the malfunction indicator light (MIL) if it detects a problem. In normal operation, the EPS indicator **2** will be on after the ignition switch is turned to ON, but EPS **1** will not work. When the engine is started, the EPS indicator will be off and the EPS starts to function.

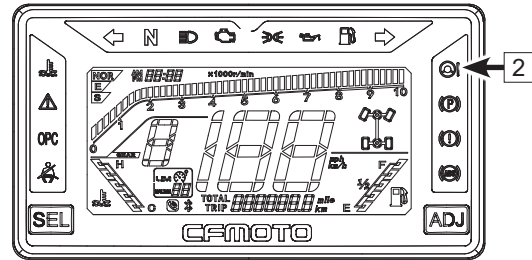
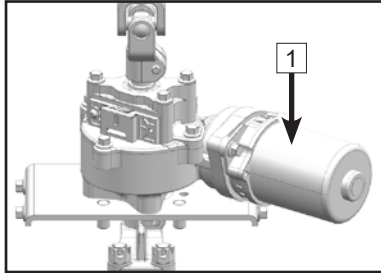

### Trouble Code

Each trouble code consists of 2 digits, denoted by the times of long flash and short flash of EPS indicator.

Times of long flash represent the tens digit;

Times of short flash represent the single digit;

Duration of long flash: 2 sec.

Duration of short flash: 1 sec.

Flash interval: 1 sec.

The flash cycle will repeat after EPS indicator turns off for 3 seconds.

NOTE: In case of an EPS failure, do not disassemble the EPS system. Check the wiring for any loose connections or blown fuse. Otherwise please contact an authorized dealer for service.

## Vehicle Issue Diagnosis

### EPS Malfunction Indicator

Times of long flash represent the tens digit;

Times of short flash represent the single digit;

Duration of long flash: 2 sec.

Duration of short flash: 1 sec.

Flash interval: 1 sec.

The flash cycle will repeat after EPS MIL indicator light turns off for 3 seconds

Stop operating the vehicle and contact your dealer immediately if the EPS system MIL is flashing or there is a loss of steering assist with the engine running.

## Vehicle Issue Diagnosis

### EPS fault diagnosis and solution

No	Failure Phenomenon	Probable Reason	Troubleshooting
1	Steering without assistance	<ol style="list-style-type: none"> <li>1.Connectors of wire is bad contact</li> <li>2.The fuse blew out</li> <li>3.Relay damage</li> <li>4.Thecontroller,motor or sensor is damaged</li> </ol>	<ol style="list-style-type: none"> <li>1.Check whether wire connectors are fully inserted</li> <li>2.Replace the fuse(30A)</li> <li>3.Replace the relay</li> <li>4.Contact with suppliers and replace it</li> </ol>
2	Power don't weighs the same for left and right	<ol style="list-style-type: none"> <li>1.The median output voltage have deviation</li> <li>2.Controller,motor or sensor is damaged</li> </ol>	<ol style="list-style-type: none"> <li>1.Disconnect motor connectors,loosen the sensor adjustment screw,adjust the sensor position to keep the voltage in <math>1.65V \pm 0.05V</math></li> <li>2.Contact with suppliers and replace it</li> </ol>
3	when system is on, the steering wheel swings on both sides	<ol style="list-style-type: none"> <li>1.Motor is mounted backwards</li> <li>2.Controller or sensor is damaged</li> </ol>	<ol style="list-style-type: none"> <li>1.Exchange the position of ( thick line) red line and black line at the motor terminal</li> <li>2.Contact with suppliers and replace it</li> </ol>
4	Steering becomes heavy	<ol style="list-style-type: none"> <li>1.Battery have power loss</li> <li>2.Motor damage (power reduction)</li> <li>3.air pressure of the tires (front) is insufficient.</li> </ol>	<ol style="list-style-type: none"> <li>1.Charge</li> <li>2.Contact with suppliers and replace it</li> <li>3.Inflate tires</li> </ol>
5	System has noise	<ol style="list-style-type: none"> <li>1.Motor damage</li> <li>2.Gap of lower steering shaft assembly or mechanical steering assembly is too large</li> <li>3.Installation of lower steering shaft assembly or mechanical steering assembly is unfirm</li> </ol>	<ol style="list-style-type: none"> <li>1.Replace</li> <li>2.Replace</li> <li>3.Check whether the installation screw is tight, reinforcement</li> </ol>

## DECLARATION

### Declaration

#### Declaration of Drivers exposure to noise level

The undersigned :Lai Min jie ,General Manager

Company name and address of the manufacturer:

ZHEJIANG CFMOTO POWER CO.,LTD.

No.116,Wuzhou Road,Yuhang Economic Development Zone,Hangzhou,311100,

Zhejiang Province P.R.China

Make(trade name of the manufacturer): CFMOTO

Type	Variant(s)	Commercial name(s) (if available)	Category, subcategory and speed index of the vehicle	The Drivers exposure to noise level result (limit: 90dB(A))
CF600ATR-2S	A	CFORCE 625	T3a	86.3
	B	CFORCE 625	T3b	90
CF600ATR-2L	A	CFORCE 625 Touring	T3a	86.3
	B	CFORCE 625 Touring	T3b	90

test method 2 of Annex XIII to EU 1322/2014

## DECLARATION

### Declaration of Vibration declaration

Driver mass		aws m/s <sup>2</sup>	CF600ATR-2S	CF600ATR-2L	Requirement
59kg±1kg	T1	Test run1	0.75	0.75	Deviation<10% between test run 1/2 and Arithmetic mean,aws<1.25m/s <sup>2</sup>
	T2	Test run2	0.73	0.73	
	A	Arithmetic mean	0.74	0.74	
98kg±5kg	T1	Test run1	0.67	0.67	Deviation<10% between test run 1/2 and Arithmetic mean,aws<1.25m/s <sup>2</sup>
	T2	Test run2	0.70	0.70	
	A	Arithmetic mean	0.69	0.69	

aws:rms value of the weighted seat vibration acceleration measured during a standard roadway test

**CFMOTO LIMITED WARRANTY**  
**CFMOTO LIMITED WARRANTY**

ZHEJIANG CFMOTO POWER CO., LTD gives a limited warranty on all components of your CFMOTO Vehicle against defects in material or workmanship within the period and under the conditions described below.

This warranty covers parts and labor charges for repair or replacement of defective parts and begins on the date of purchase by the original retail purchaser. This warranty is transferable to another owner during the warranty period through a CFMOTO dealer, but any such transfer will not extend the original term of the warranty.

**LIMITATIONS OF LIABILITY**

THIS WARRANTY IS EXPRESSLY GIVEN AND ACCEPTED IN LIEU OF ANY AND ALL OTHER WARRANTIES, EXPRESSED OR IMPLIED, INCLUDING BUT NOT LIMITED TO ANY IMPLIED WARRANTY OF MERCHANTABILITY OR FITNESS FOR A PARTICULAR PURPOSE. TO THE EXTENT THAT THEY CAN NOT BE DISCLAIMED, THE IMPLIED WARRANTIES ARE LIMITED IN DURATION TO THE LIFE OF THE EXPRESS WARRANTIES. INCIDENTAL AND CONSEQUENTIAL DAMAGES ARE EXCLUDED FROM COVERAGE UNDER THIS WARRANTY. SOME STATES/PROVINCES DO NOT ALLOW FOR THE DISCLAIMERS, LIMITATIONS AND EXCLUSIONS IDENTIFIED ABOVE, AS A RESULT, THEY MAY NOT APPLY TO YOU. THIS WARRANTY GIVES YOU SPECIFIC RIGHTS, AND YOU MAY ALSO HAVE OTHER LEGAL RIGHTS WHICH MAY VARY FROM STATE TO STATE, OR PROVINCE TO PROVINCE.

Neither the distributor, CFMOTO dealer nor any other person has been authorized to make any affirmation, representation or warranty regarding the product, and other than those contained in this limited warranty, if made, shall not be enforceable against CFMOTO. CFMOTO reserves the right to modify this warranty at any time, being understood that such modification will not alter the warranty conditions applicable to the products sold while this warranty is in effect.

## CFMOTO LIMITED WARRANTY

### REGISTRATION

The Dealer must register the vehicle online and provide the completed registration form to ZHEJIANG CFMOTO POWER CO., LTD within ten (10) days of completing the sale of the vehicle. Please note that NO warranty claims will be processed unless the product warranty online registration form is completed and the form is received by ZHEJIANG CFMOTO POWER CO., LTD from the Dealer. Initial dealer preparation and set-up of your vehicle is very important in ensuring trouble-free operation. Purchasing a machine in the crate or without proper dealer set-up will void your warranty coverage.

### EXCLUSIONS-ARE NOT WARRANTED

The following are not warranted under any circumstances:

1. Normal wear and tear;
2. Damage caused by abuse, abnormal use, neglect or operation of the product in a manner inconsistent with the recommended operation described in the Owner's Manual;
3. Damage caused by failure to provide proper maintenance and/or storage, as described in the Owner's Manual;
4. Damage resulting from removal of parts, improper repairs, service, maintenance, or use of parts not manufactured or approved by CFMOTO or resulting from repairs done by a person that is not an authorized servicing CFMOTO dealer;
5. Routine maintenance items, tune-ups, adjustments;
6. Damage resulting from accident, submersion, fire, theft, vandalism or any force majeure;
7. Operation with fuels, oils or lubricants which are not suitable for use with the product (see the Owner's Manual);
8. Damages from rust, corrosion or exposure to the elements;
9. Damage resulting from water or snow ingestion;
10. Damage resulting from the racing or any other competitive activity
11. Damage resulting from use of vehicle as a rental vehicle.

### **CFMOTO LIMITED WARRANTY**

12. Damage resulting from the vehicle has been altered or modified in such a way so as to adversely affect its operation, performance or durability, or has been altered or modified to change its intended use;

13. Incidental or consequential damages, or damages of any kind including without limitation towing, storage, telephone, rental, taxi, inconvenience, insurance coverage, loan payments, loss of time, loss of income etc.

### **WARRANTY COVERAGE PERIOD**

This warranty will be in effect from the date of delivery to the first retail consumer. For the applicable period below:

Twelve (12) CONSECUTIVE MONTHS, for private use owners. Any vehicles used for commercial purposes will have their warranty period reduced to six (6) months.

This warranty period is the CFMOTO factory's basic warranty period, and the duration of this warranty may vary by international region based upon local laws, regulations and distributors' policy. Please Note the warranty period you get from dealers may be the same or more than this limited warranty, but not less.

If ZHEJIANG CFMOTO POWER CO., LTD covers a full engine replacement or a complete vehicle replacement under this warranty, the warranty period does not get extended and remains the same as the original purchase date of the vehicle at issue.

### **LIMITATIONS OF WARRANTIES AND REMEDIES**

The CFMOTO limited warranty excludes damages or failures caused by abuse, accident, fire, or any other cause other than a defect in materials or workmanship and provides no coverage for consumable components, general wear items, or any parts exposed to friction surfaces, stresses, environmental conditions and/or contamination for which they were not designed or not intended, including but not limited to the following items:

## CFMOTO LIMITED WARRANTY

- Bushings
- Wheels and tires
- Suspension components
- Seat components
- Clutches and components
- Steering components
- Batteries
- Light bulbs/Sealed beam lamps
- Filter
- Lubricants
- Bearings
- Finished and unfinished surface
- Engine components
- Drive belts
- Hydraulic components and fluids
- Circuit breakers/Fuses
- Spark plugs
- Sealants
- Coolants
- Bearings

### CONDITIONS TO HAVE WARRANTY COVERAGE

This warranty coverage is available only if each of the following conditions has been fulfilled:

1. The CFMOTO Vehicle must be purchased as new and unused by its first owner from a CFMOTO dealer authorized to distribute CFMOTO Vehicle in the country in which the sale occurred;
2. The CFMOTO specified predelivery inspection process must be completed and documented and signed by the purchaser;
3. The CFMOTO Vehicle must have undergone proper registration by an authorized CFMOTO dealer;
4. The CFMOTO Vehicle must be purchased in the country in which the purchaser resides;
5. Routine maintenance outlined in the Owner's manual must be timely performed in order to maintain warranty coverage. CFMOTO reserves the right to make warranty coverage contingent upon proof of proper maintenance. CFMOTO will not honor this limited warranty to any private use owner or commercial use owner if one of the preceding conditions has not been met. Such limitations are necessary in order to allow CFMOTO to preserve both the safety of its products, and also that of its consumers and the general public.

## **CFMOTO LIMITED WARRANTY**

### **HOW TO OBTAIN WARRANTY SERVICE**

The customer must cease using the CFMOTO Vehicle upon the appearance of an anomaly. The customer must notify a servicing CFMOTO dealer within three (3) days of the appearance of a defect, and provide it with reasonable access to the product and reasonable opportunity to repair it. The customer must also present to the authorized CFMOTO dealer, proof of purchase of the product and must sign the repair/work order prior to starting the repair in order to validate the warranty repair. All parts replaced under this limited warranty become the property of CFMOTO.

### **WHAT CFMOTO DEALER WILL DO**

A CFMOTO authorized Dealer must perform warranty coverage repairs at no charge to the customer, even if they are not the dealer that sold the CFMOTO vehicle to the customer and must use CFMOTO OEM parts for all warranty repairs. All vehicles sold by the dealer must be inspected and tested by the dealer to ensure proper performance and operation prior to delivery to the customer. No vehicles may be delivered to a customer without first passing a dealer inspection and an operational test.

### **EXPORTED PRODUCTS**

EXCEPT WHERE SPECIFICALLY REQUIRED BY LAW, THERE IS NO WARRANTY OR SERVICE BULLETIN COVERAGE ON THIS PRODUCT IF IT IS SOLD OUTSIDE THE COUNTRY OF THE SELLING DEALER'S AUTHORIZED LOCATION. This policy does not apply to products that have received authorization for export from CFMOTO. Dealers may not give authorization for export. You should consult an authorized dealer to determine this product's warranty or service coverage if you have any questions. This policy does not apply to products registered to government officials or military personnel on assignment outside the country of the selling dealer's authorized location. This policy does not apply to Safety Bulletins.



**CFMOTO**

EXPERIENCE MORE TOGETHER

9DS#-380102-7000 EU206